

PLASTIC MODEL KITS  
LIMITED EDITION  
CAT.NO.72253



SPAN : 406 mm  
LENGTH : 331 mm  
PARTS : 159 pieces  
**SCALE:1/72**

 Due to the fact that Il-14 piston engine aircraft had to be replaced by the same aircraft class with turbo engines, in 1957, OKB Antonov (Antonov Design Bureau) proposed to design a new aircraft on short to medium haul trips and with possibility to operate from small unprepared airports. Its performances and power plant provided the operation in high mountains and in a wide range of temperatures. The An-24 prototype made its maiden flight on April 20, 1960. In 1962, serial aircrafts were put into Aeroflot service. In 1963, the first 50-seat An-24V aircrafts started to flight between Moscow, Voronezh and Saratov. ▯

Next versions are: An-24V Series II - 50-seat mixed passenger, cargo and freight version; An-24RV - similar to the previous version, but fitted with a 1,985-lb (900-kg) thrust auxiliary turbojet engine for engine independent starting and for increasing the power to weight ratio at take off; An-24T - freight transport version with a cargo door in the tail fuselage, two ventral fins from the exteriorly of the cargo door, overhead-track hoist and airdrop equipment; An-24RT - similar to the An-24T, but fitted with an auxiliary turbojet engine as on the An-24RV; An-24LP-forest fireproof version. Totally, 1100 An-24 aircrafts for civil and military operations were produced.

The model is executed on technology short run and is intended only for experienced modelers! Word-wide distributor for AMODEL kits : IBG, Warszawa, Poland Fax:(4822)842-56-29 ; E-Mail:ibgsc@ibg.com.pl

Модель виконана за технологією Short run і призначена лише для досвідчених модельстів Дистрибутор моделей AMODEL : IBG, Варшава, Польща Факс:(4822) 842-56-29 ; E-Mail:ibgsc@ibg.com.pl



## USED SYMBOLS / ВИКОРИСТОВУВАНІ СИМВОЛИ

**1** STAGES OF ASSEMBLY  
ЕТАПИ СКЛАДАННЯ

**1** NUMBER PARTS  
НОМЕР ДЕТАЛІ

**1** APPLY DECALS  
НАНЕСТИ ДЕКАЛЬ

**A** TO PAINT  
ЗАБАРВИТИ

 GLUE  
КЛЕЇТИ

 DON'T GLUE  
НЕ КЛЕЇТИ

**?** OPTIONAL  
НА ВИБІР

 MAKE A HOLE  
ВИКОНАТИ ОТВІР

 DETACH WITH KNIFE  
ВІДОКРЕМИТИ  
НОЖЕМ

**2x** QUANTITY OF OPERATIONS(PARTS)  
КІЛЬКІСТЬ ОПЕРАЦІЙ (ДЕТАЛЕЙ)

DECALS FOR TWO VERSIONS OF COLOURING  
ДЕКАЛЬ ДЛЯ ДВОХ ВАРІАНТІВ ФАРБУВАННЯ

159 DETAILS FOR ASSEMBLY OF ONE MODEL  
159 ДЕТАЛЕЙ ДЛЯ ЗБИРАННЯ ОДНІЄЇ МОДЕЛІ

 PARTS NOT FOR USE  
ПРИ СКЛАДАННІ НЕ ВИКОРИСТОВУЄТЬСЯ

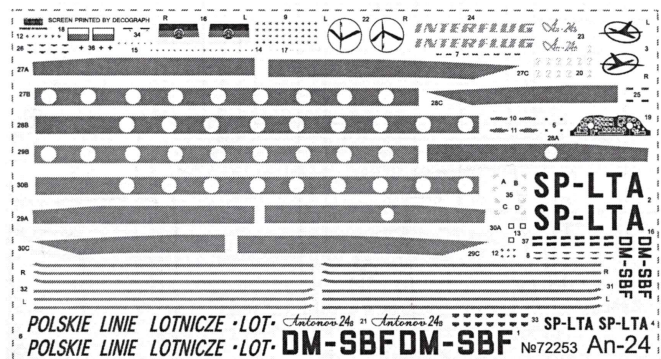

## USED PAINTS / ВИКОРИСТОВУВАНІ ФАРБИ

**A**   
HUMBROL 147  
LIGHT GREY  
СВІТЛО СІРИЙ

**B**   
HUMBROL 27002  
POLISHED ALUMINIUM  
ПОЛ. АЛЮМІНІЙ

**C**   
HUMBROL 27003  
POLISHED STEEL  
ПОЛІР. СТАЛЬ

**D**   
HUMBROL 33  
BLACK  
ЧОРНИЙ

**E**   
HUMBROL 24  
YELLOW  
ЖОВТИЙ

**F**   
HUMBROL 87  
STEEL GREY  
СТАЛІВ. СІРИЙ

**G**   
HUMBROL 101  
MID GREEN  
СЕРЕД. ЗЕЛЕНИЙ

**K**   
HUMBROL 27004  
GUN METAL  
МЕТАЛЕВИЙ

**L**   
HUMBROL 34  
WHITE  
БІЛИЙ

**M**   
HUMBROL 19  
RED  
ЧЕРВОНИЙ

**N**   
HUMBROL 11  
SILVER  
СРІБЛЯСТИЙ

**O**   
HUMBROL 14  
FRENCH BLUE  
БЛАКІТНИЙ

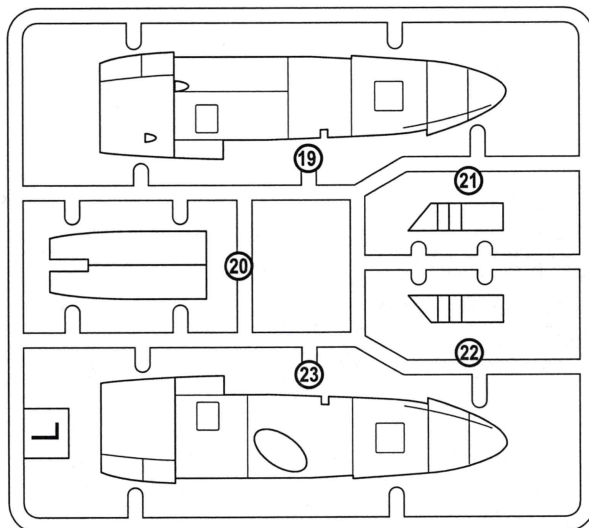
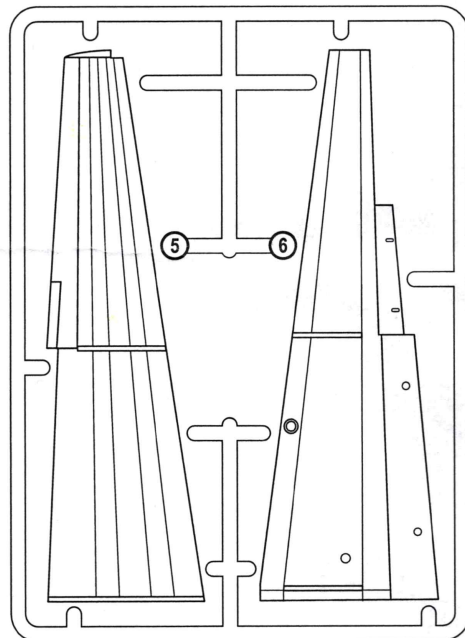
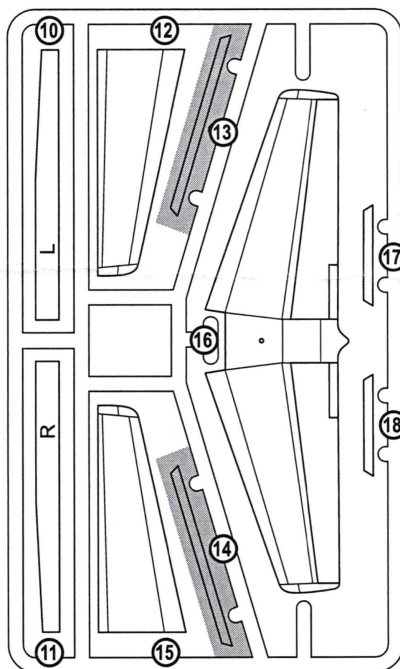
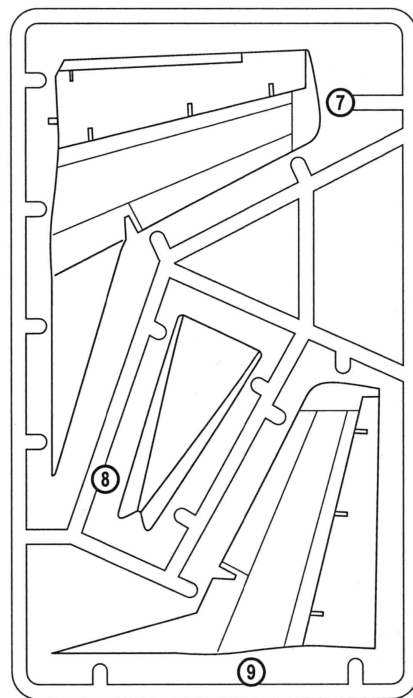
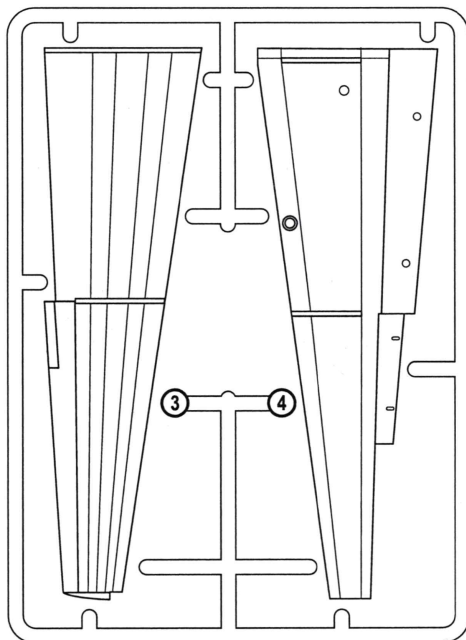
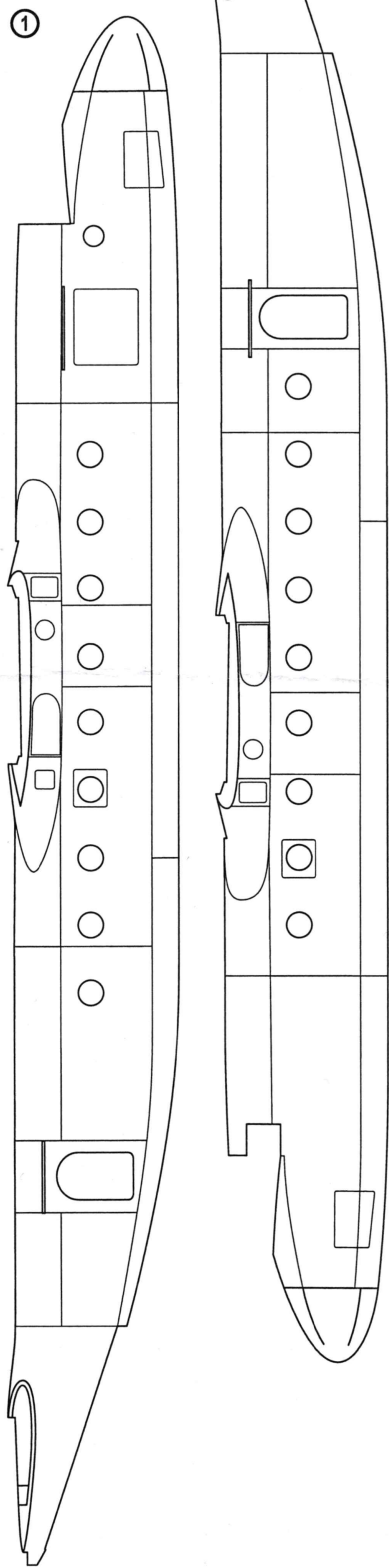

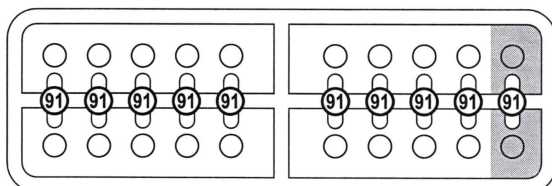
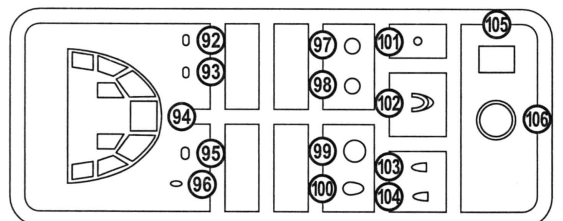
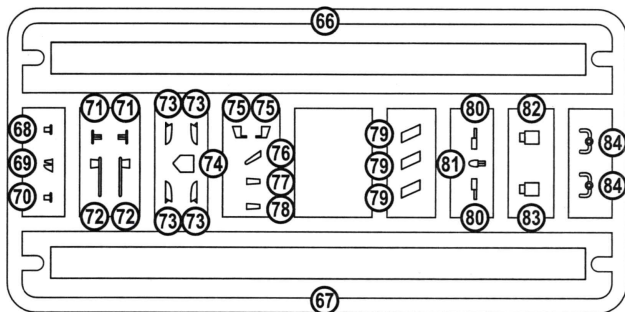
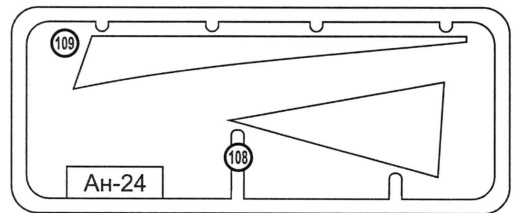
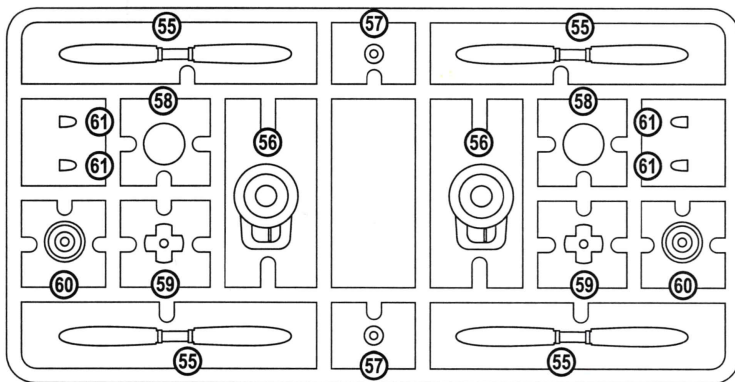
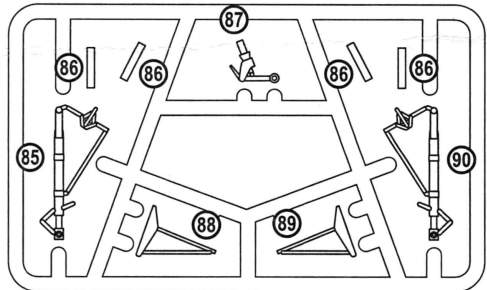
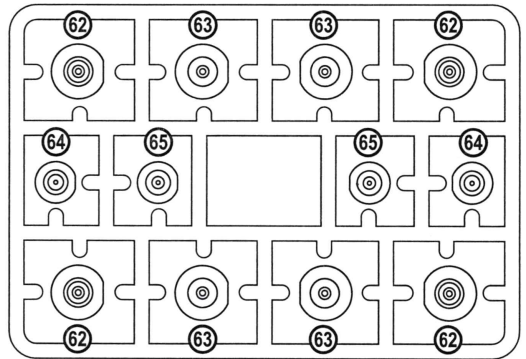
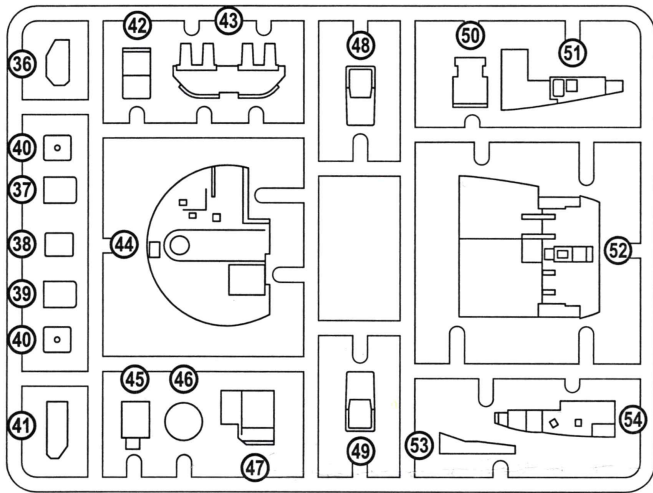
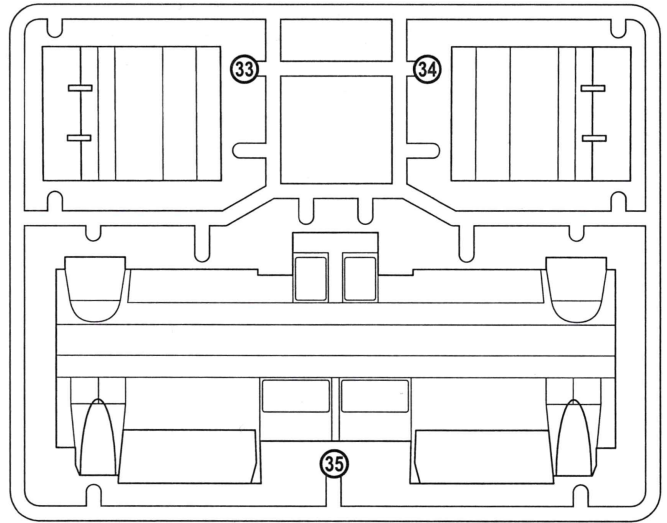
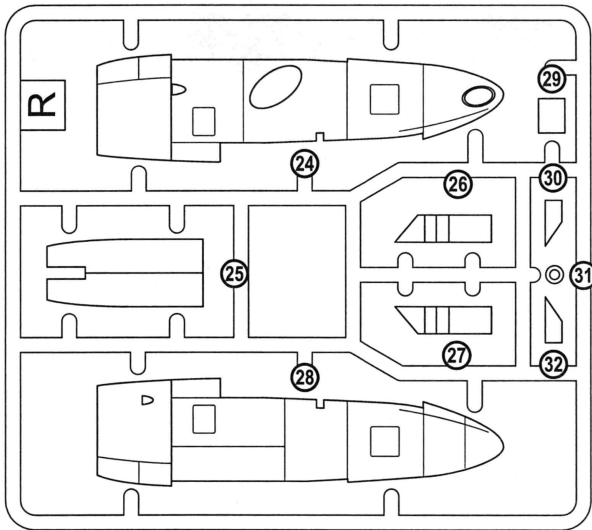

**1** 36 38 41 43 44 51 52 53 54 83 2x 84

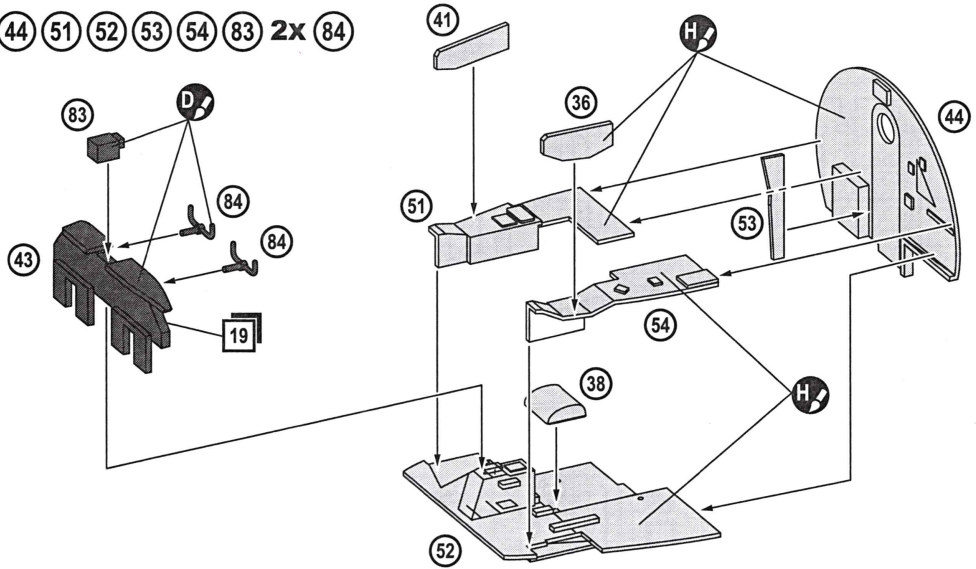

**2** 37 39 2x 40 48 49 2x 80 1

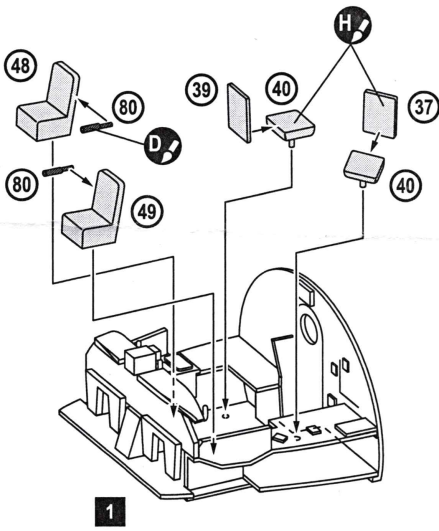

**3** 42 47 74 82 2

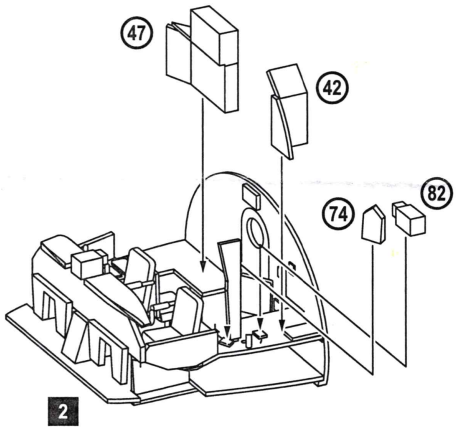

**4** 50 94

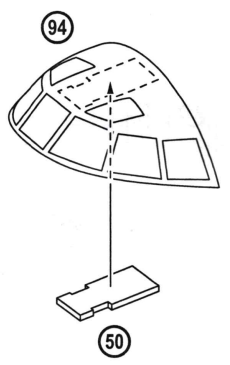

**5** 1 45 66 9x 91 99

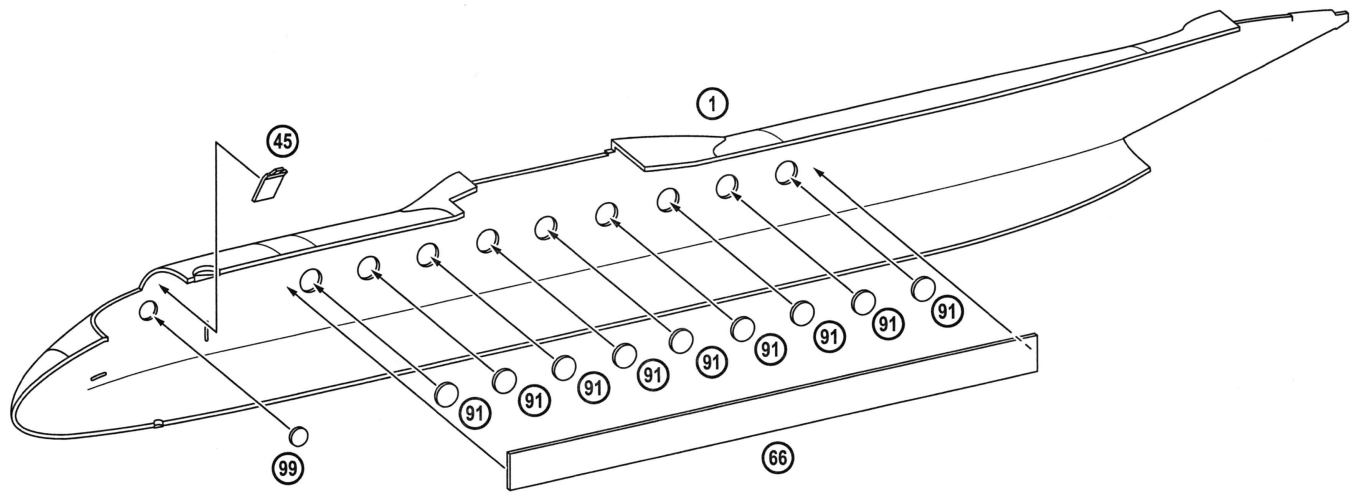

6  2 67 9x 91 92 93 95

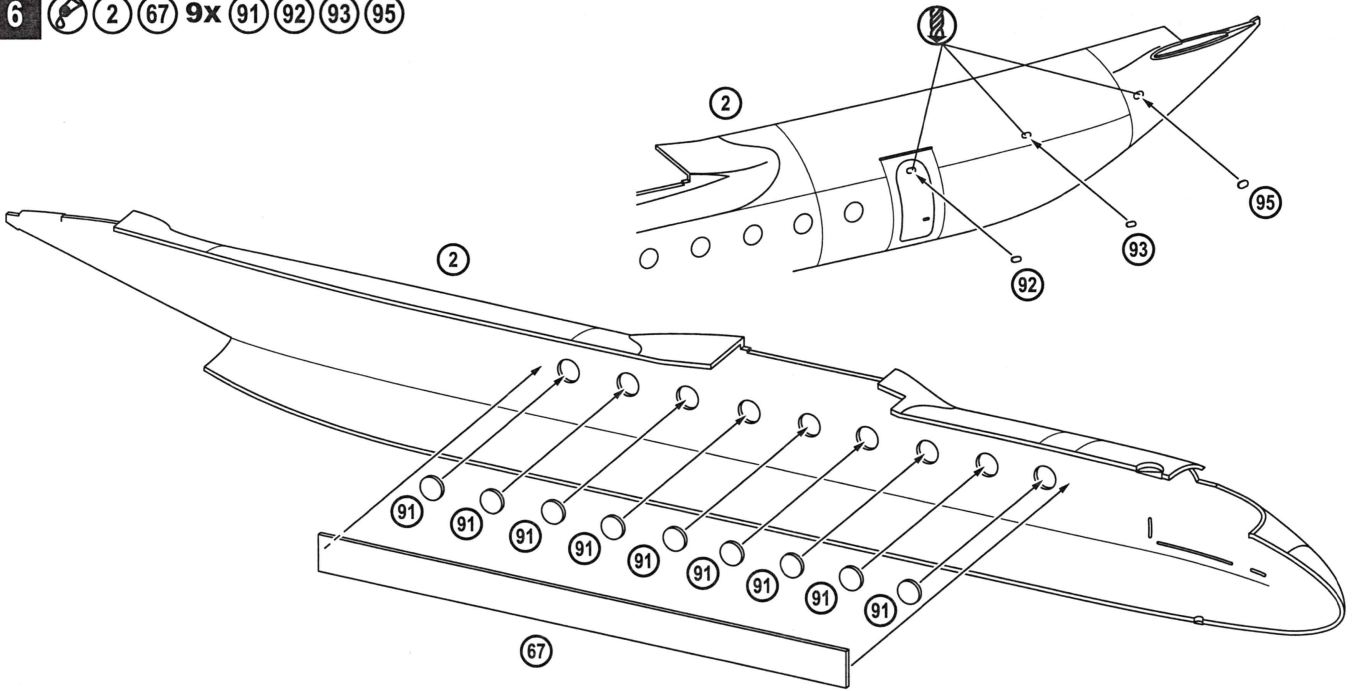

7  12 15 16

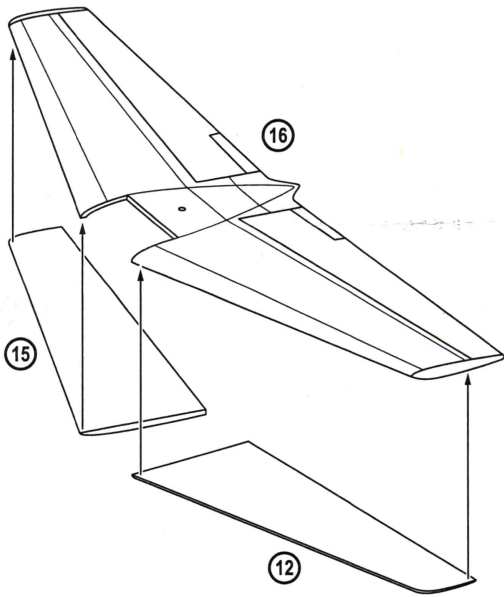

8  7 9 101 102

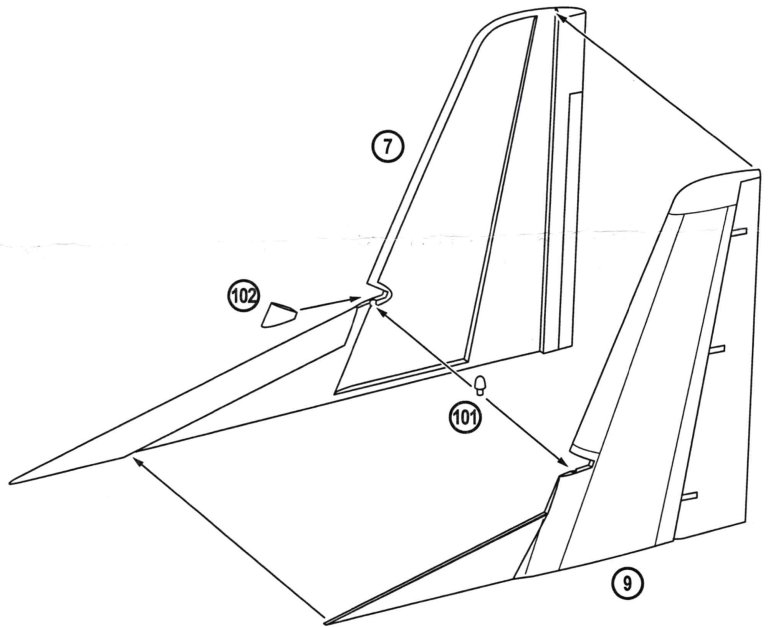

9  2x 62 2x 63 85

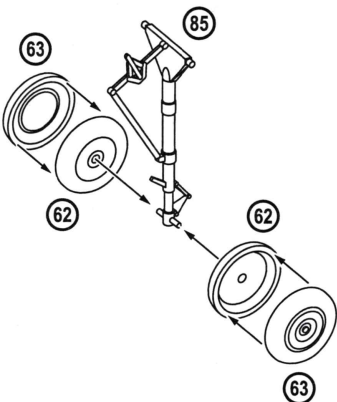

10  2x 62 2x 63 90

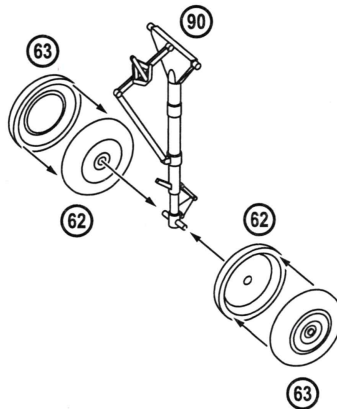

11  2x 64 2x 65 87

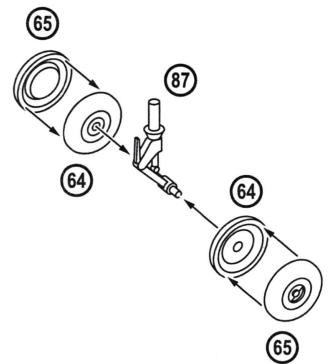

**12**  19 20 21 22 23 56 2x 61 2x 86 88 9

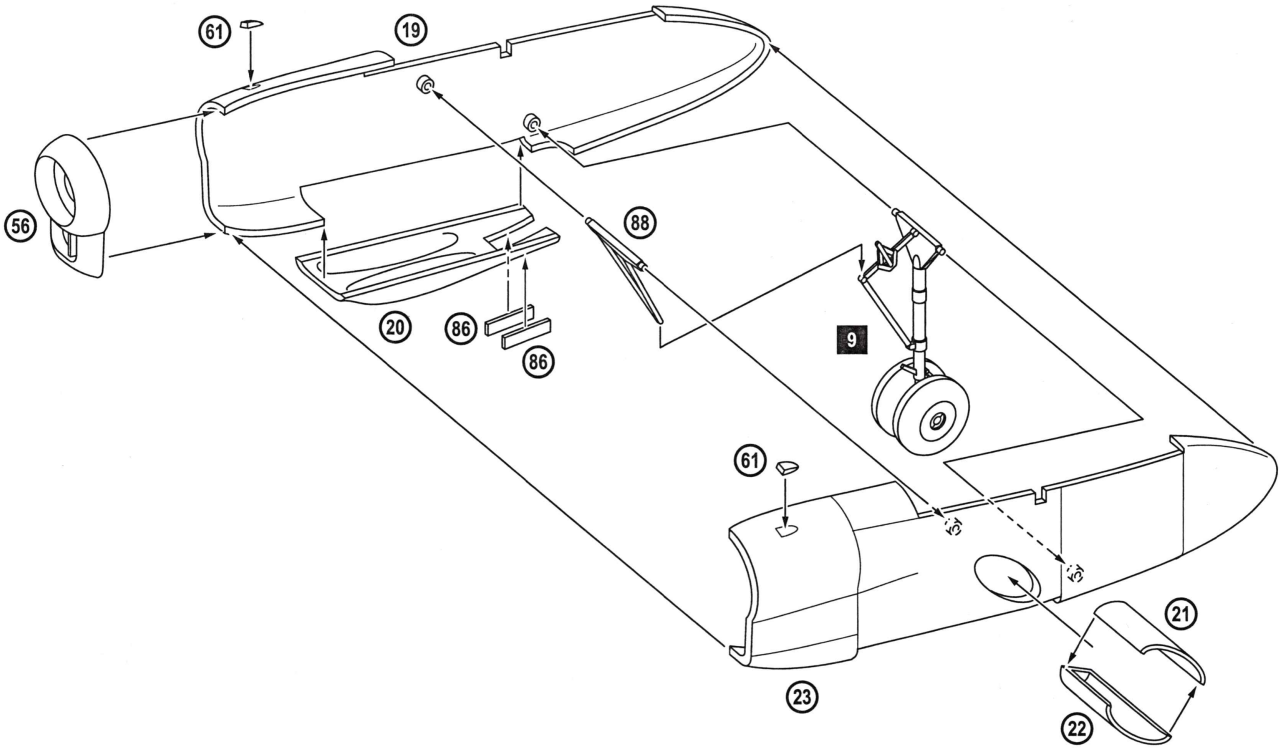

**13**  24 25 26 27 28 29 30 31 32 56  
2x 61 2x 86 89 10

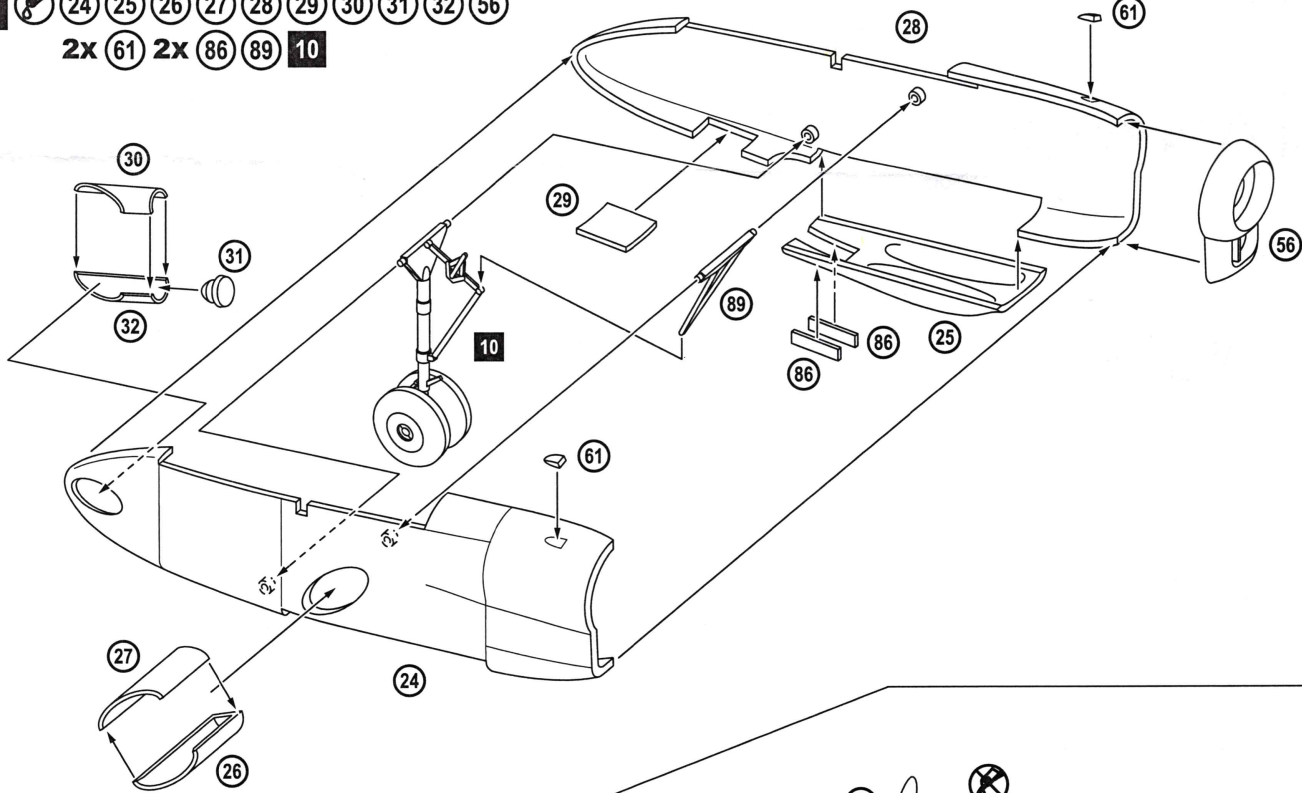

**14**  4x 55 2x 57 2x 58 2x 59 2x 60  
2X

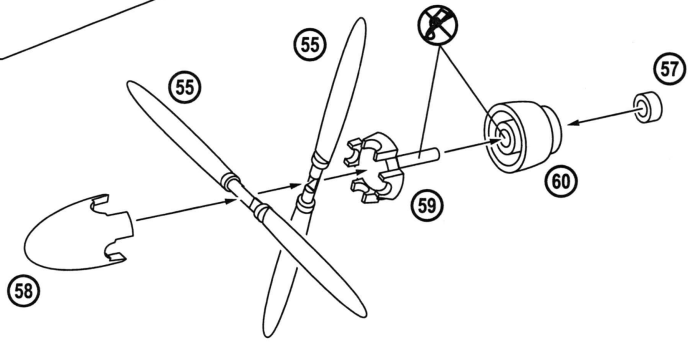

15 8 5 6 77 97 103

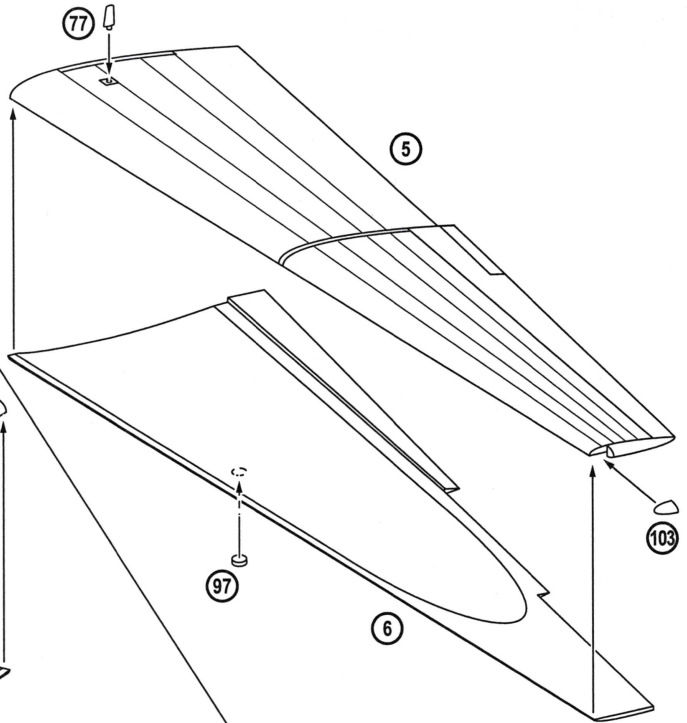

16 8 3 4 78 98 104

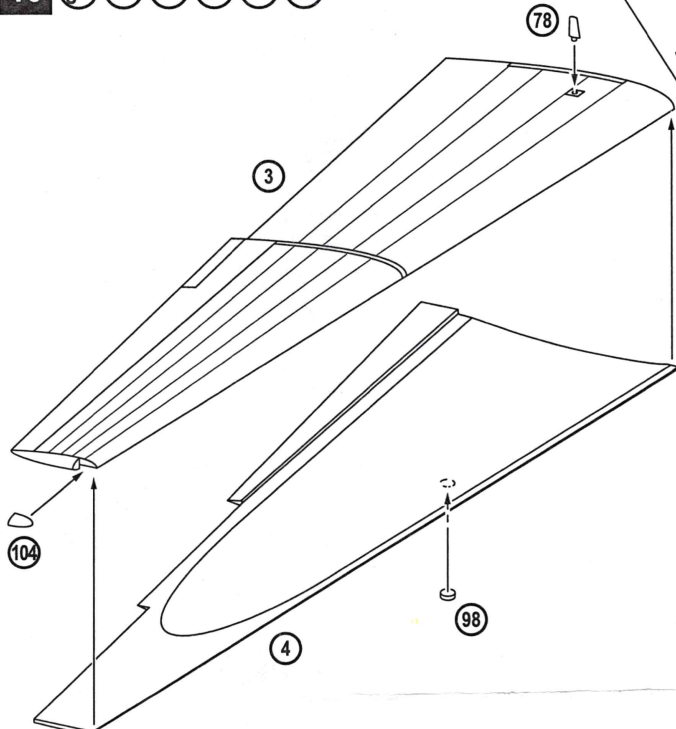

8

17 8 10 11 33 34 35 46 96 105 106 3 4 5 6 7 8

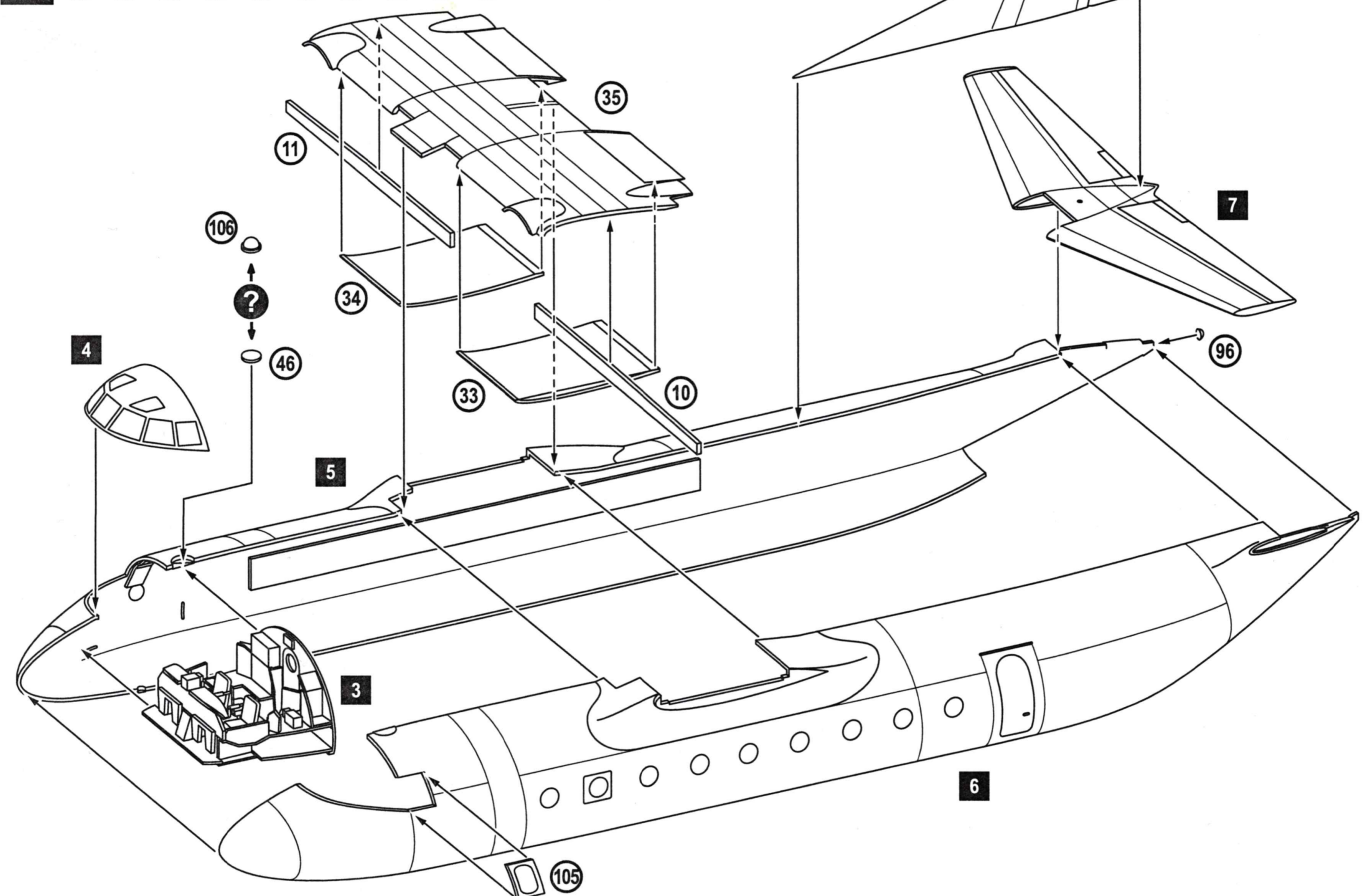

18  11 12 13 15 16 17

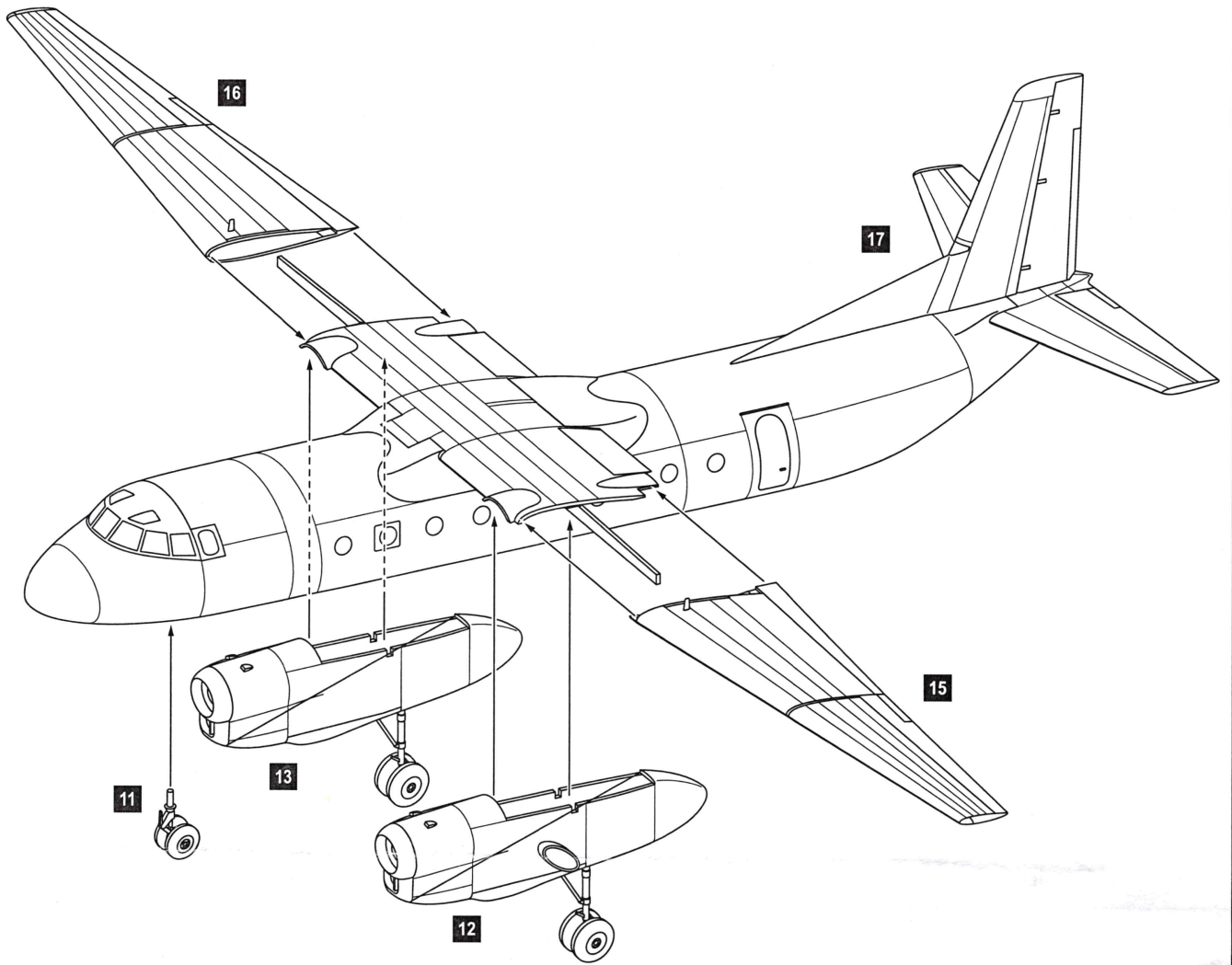

19  8 17 18 2x 71 4x 73 79 100 108 109 18

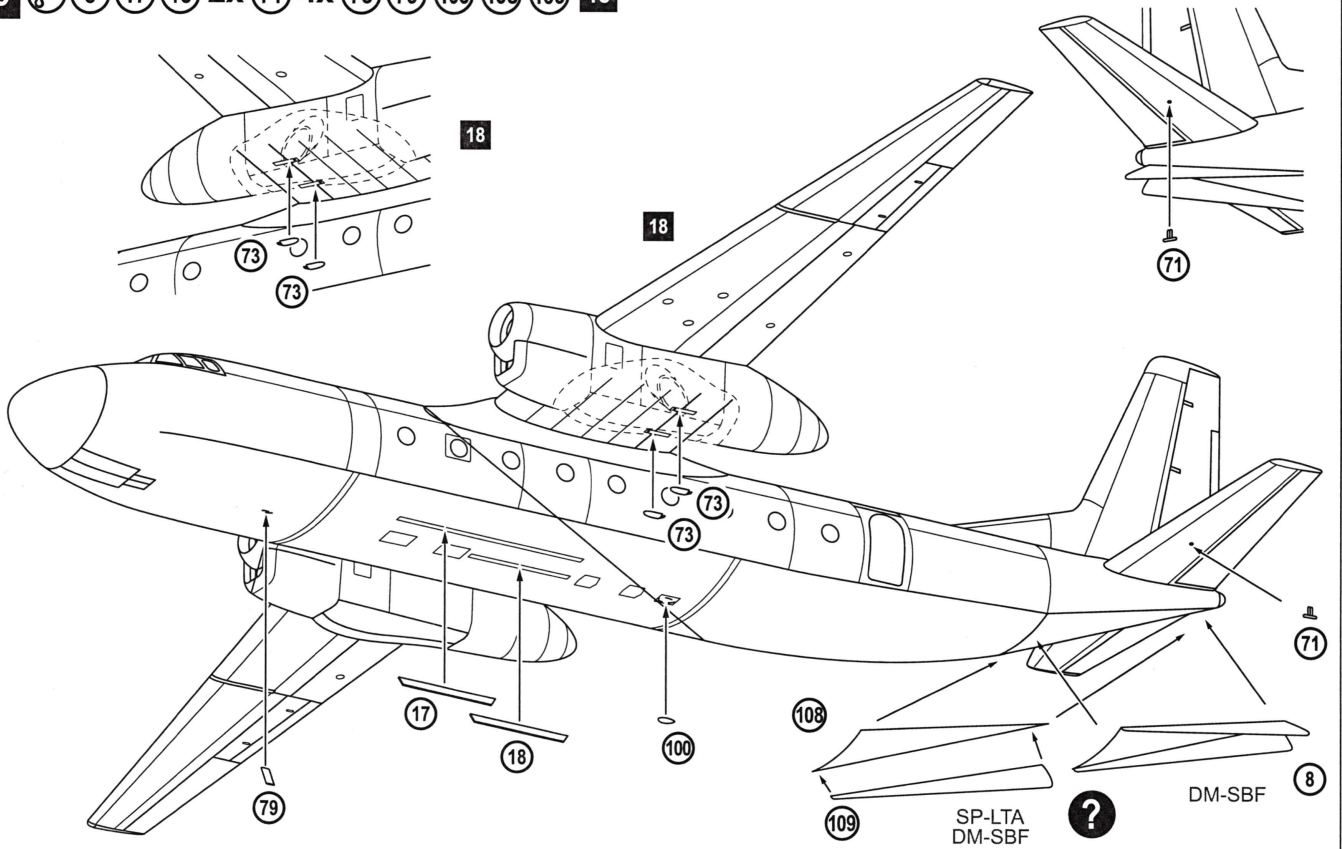



20  69 70 72 75 76 19

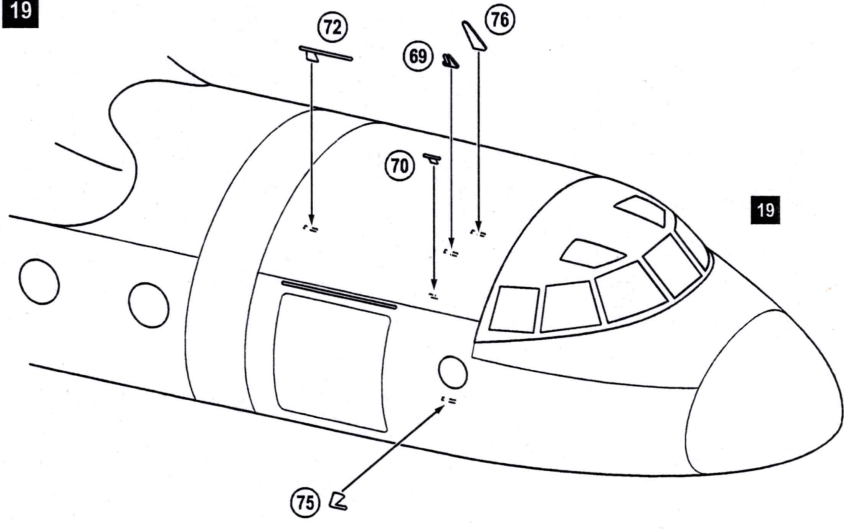

21  68 72 75 79 81 20

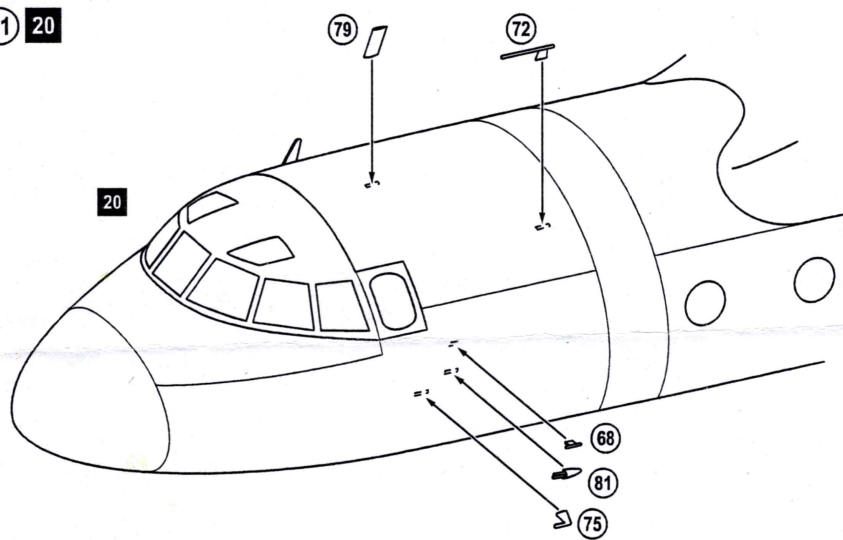

22  2x 14 21

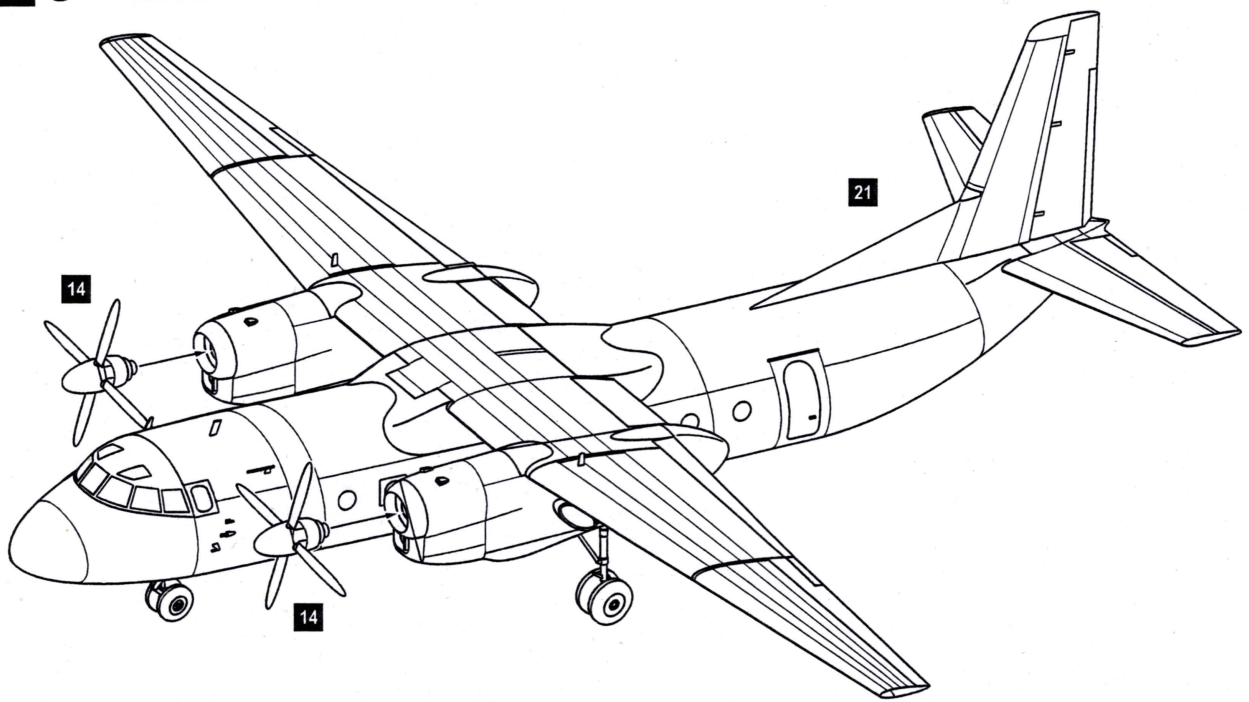

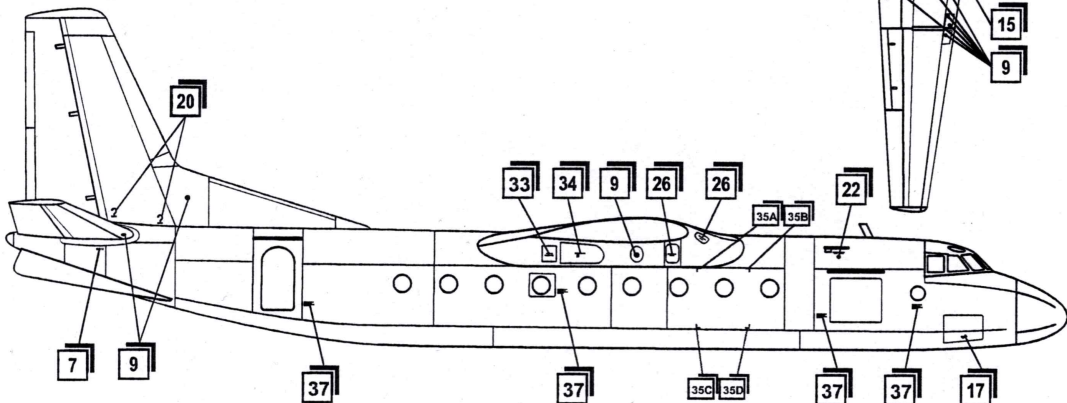
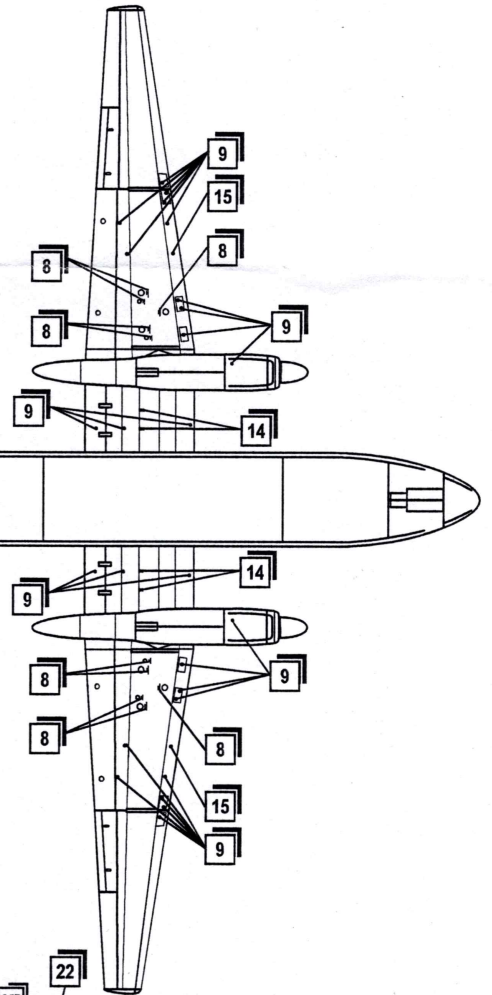
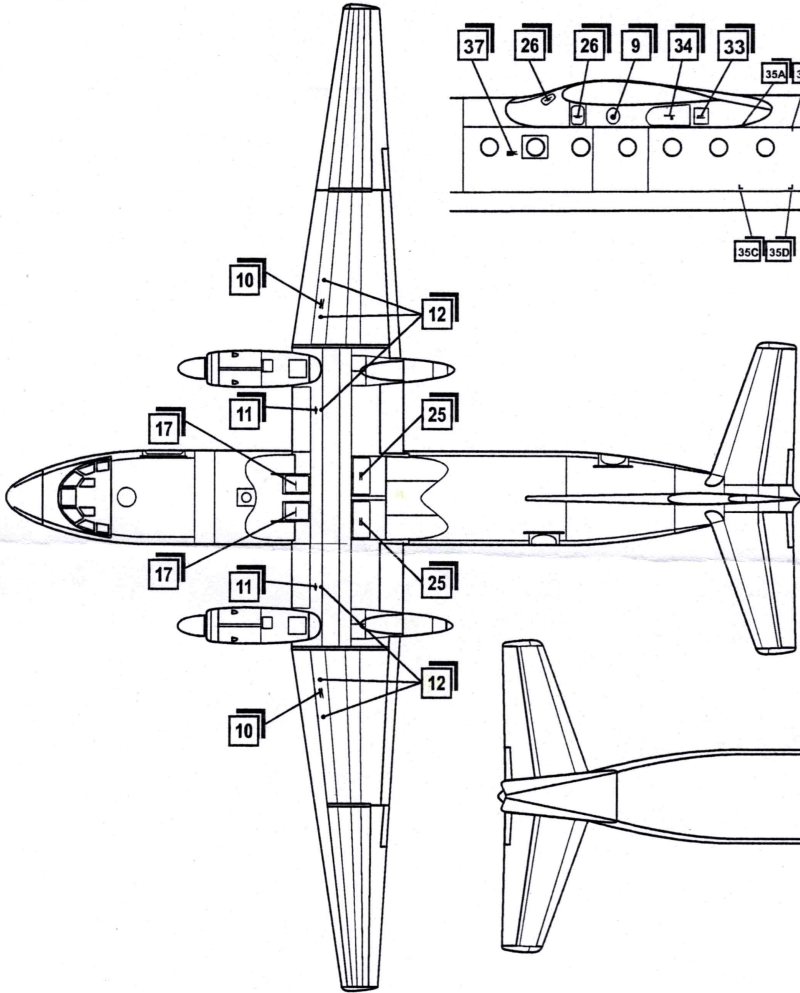
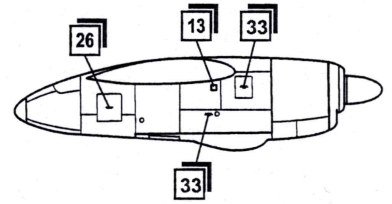
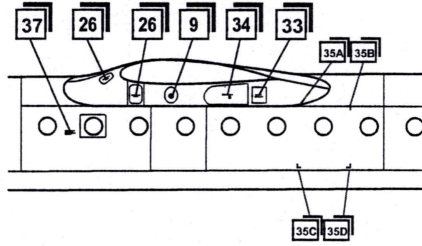
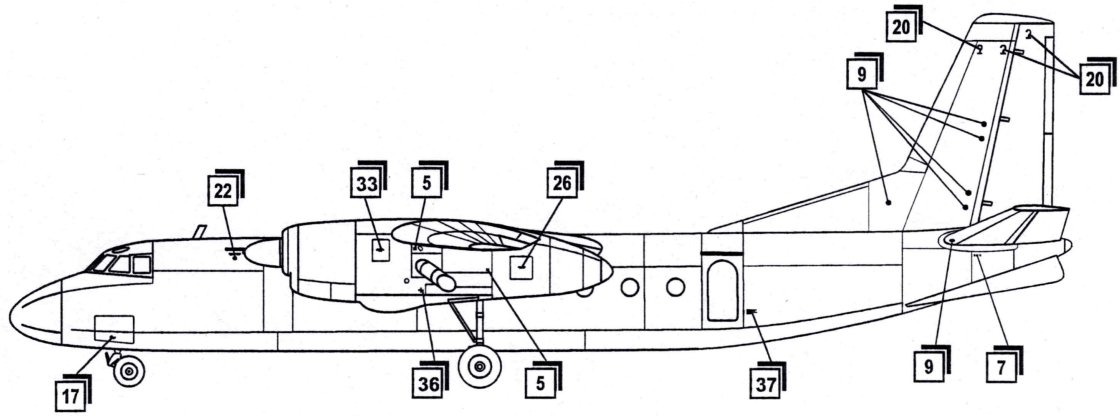

# An-24B Poland

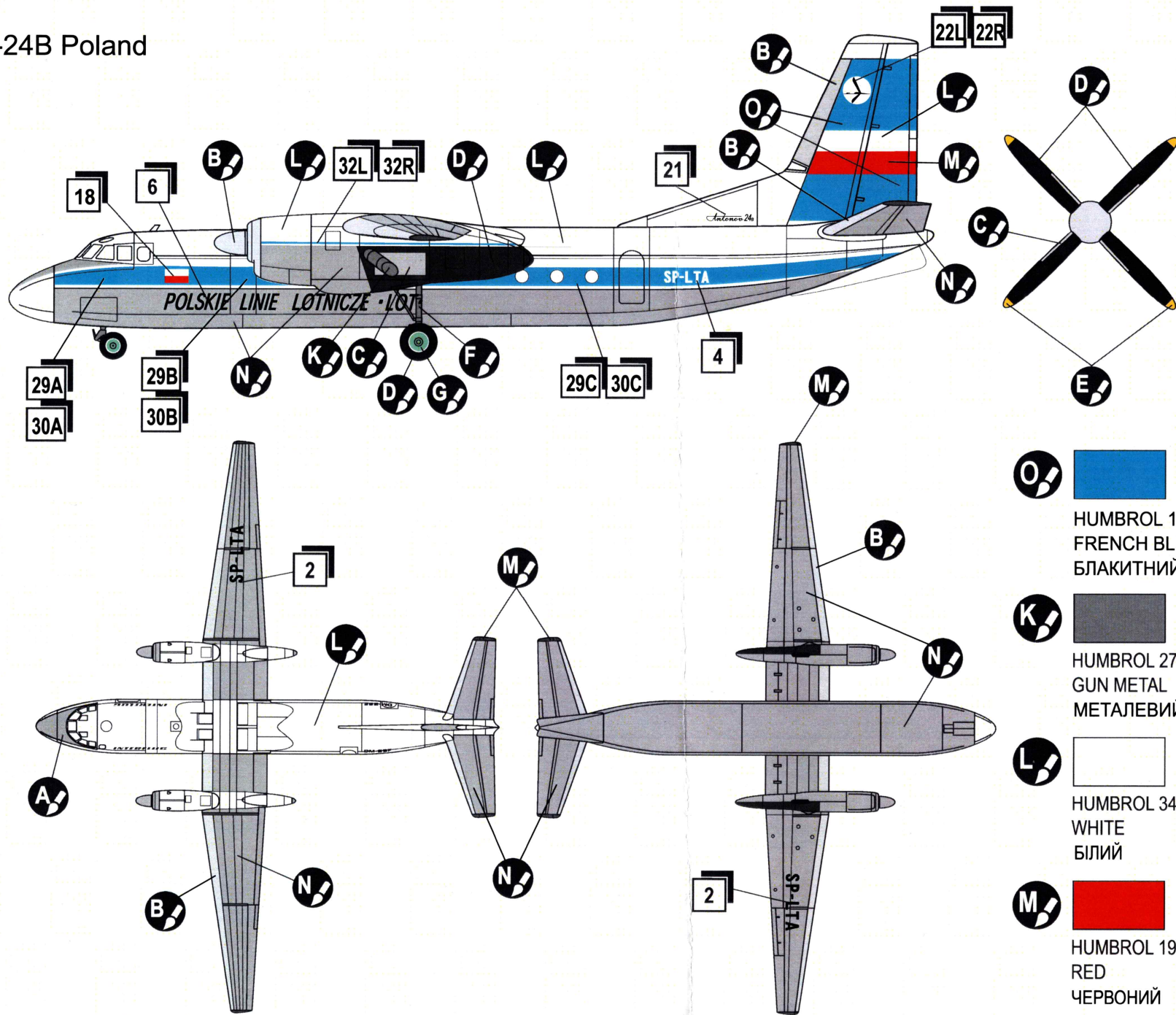

- |  |          |  |
|--|----------|--|
|  | <b>A</b> | HUMBROL 147<br>LIGHT GREY<br>СВІТЛО СІРИЙ        |
|  | <b>B</b> | HUMBROL 27002<br>POL. ALUMINIUM<br>ПОЛ. АЛЮМІНІЙ |
|  | <b>C</b> | HUMBROL 27003<br>POLISHED STEEL<br>ПОЛІР. СТАЛЬ  |
|  | <b>D</b> | HUMBROL 33<br>BLACK<br>ЧОРНИЙ                    |
|  | <b>E</b> | HUMBROL 24<br>YELLOW<br>ЖОВТИЙ                   |
|  | <b>F</b> | HUMBROL 87<br>STEEL GREY<br>СТАЛЕВ. СІРИЙ        |
|  | <b>G</b> | HUMBROL 101<br>MID GREEN<br>СЕРЕД. ЗЕЛЕНИЙ       |
|  | <b>O</b> | HUMBROL 14<br>FRENCH BLUE<br>БЛАКИТНИЙ           |
|  | <b>K</b> | HUMBROL 27004<br>GUN METAL<br>МЕТАЛЕВИЙ          |
|  | <b>L</b> | HUMBROL 34<br>WHITE<br>БІЛИЙ                     |
|  | <b>M</b> | HUMBROL 19<br>RED<br>ЧЕРВОНИЙ                    |

# An-24B DDR

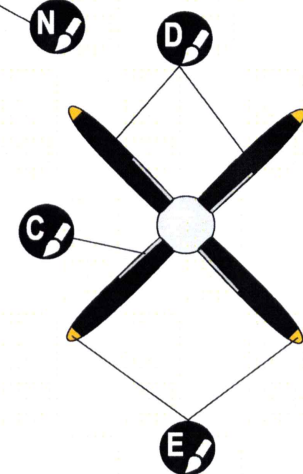
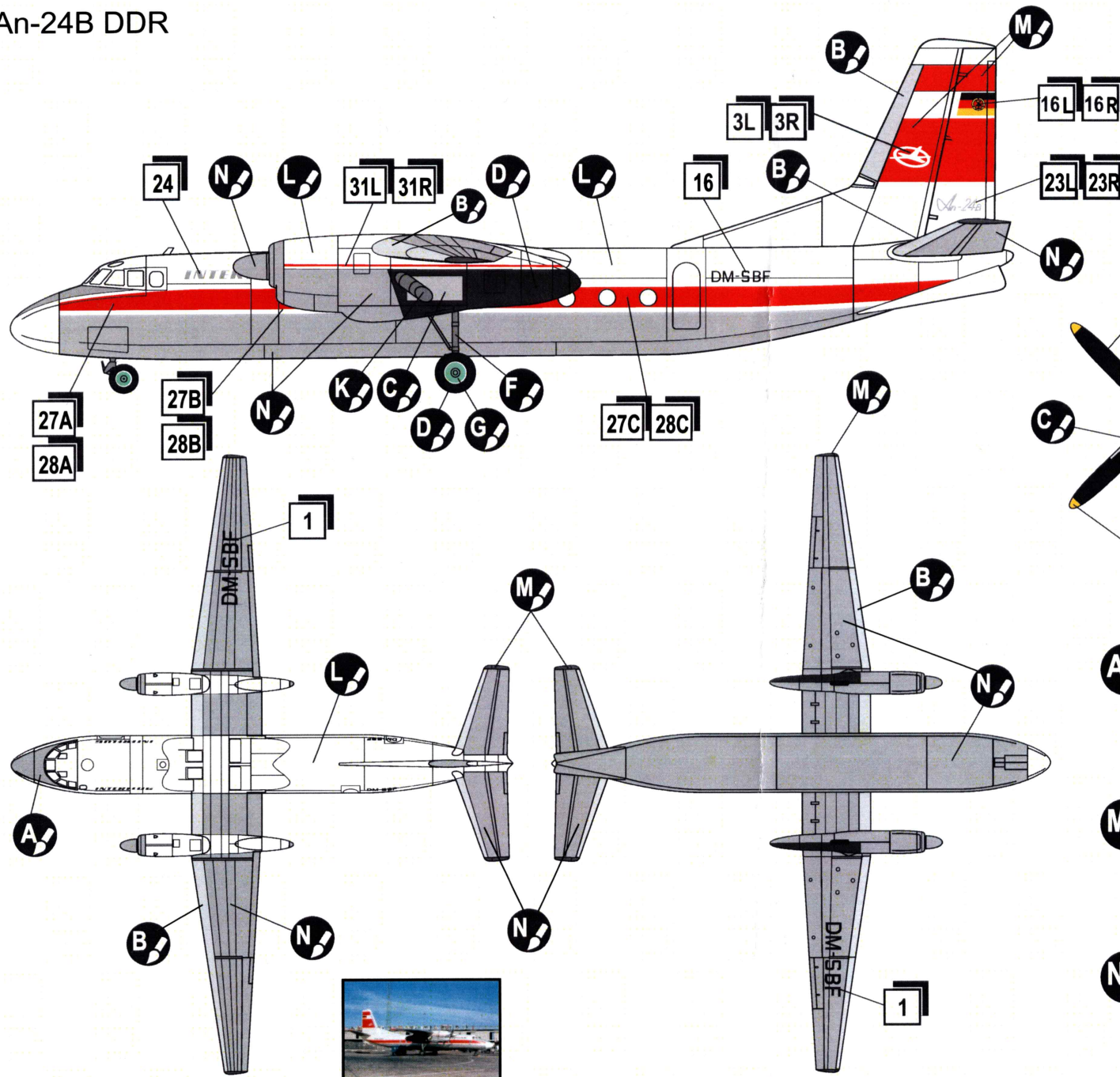

- C**  HUMBROL 27003  
POLISHED STEEL  
ПОЛІР. СТАЛЬ
- D**  HUMBROL 33  
BLACK  
ЧОРНИЙ
- E**  HUMBROL 24  
YELLOW  
ЖОВТИЙ
- F**  HUMBROL 87  
STEEL GREY  
СТАЛЕВ. СІРИЙ
- G**  HUMBROL 101  
MID GREEN  
СЕРЕД. ЗЕЛЕНИЙ
- K**  HUMBROL 27004  
GUN METAL  
МЕТАЛЕВИЙ
- L**  HUMBROL 34  
WHITE  
БІЛИЙ
- A**  HUMBROL 147  
LIGHT GREY  
СВІТЛО СІРИЙ
- M**  HUMBROL 19  
RED  
ЧЕРВОНИЙ
- N**  HUMBROL 11  
SILVER  
СРІБЛЯСТИЙ

PRINTED IN URSATNE SCREEN PRINTED BY DECOGRAPH

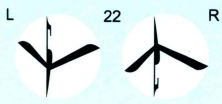
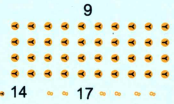
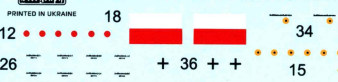

INTERFLUG  
INTERFLUG

An-24b  
An-24b

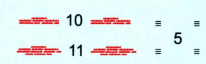
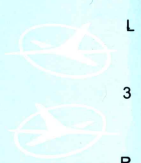

A B  
35  
C D  
SP-LTA  
SP-LTA

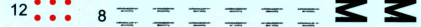

POLSKIE LINIE LOTNICZE · LOT ·  
POLSKIE LINIE LOTNICZE · LOT ·

Antonov 24B Antonov 24B

DM-SBF DM-SBF

№72253 An-24