

Clear Prop!

STARTER



I-16 TYPE 5

FINNISH
SERVICE

1:72

model # CP72048



scale model kit

SPAN: 125,2 mm

LENGTH: 84,5 mm

NUMBER OF PARTS: 102 pcs

1

stages
of assembly



optional

A

variants
of assembly



glue by
super glue

A1

part
number



do not
glue



fill with
putty



make
a hole

1

apply
decals



detach
with knife



apply the
adhesive
mask



paint



bend



repeat the
operation
N times

Role

National origin

Manufacturer

First flight

Primary users

Produced

Number built

Fighter

Soviet Union

USSR, Plant No. 21, Plant No. 39, Plant No. 153, Plant No. 458

30 December 1933 (TsKB-12)

Soviet Air Force, Spanish Republican Air Force, Chinese Nationalist Air Force

November 1934 – 1942

10,292 (6,848 fighters and 3,444 trainers)

I-16 (TsKB-12) - a Soviet single-engine monoplane fighter of the 1930s, created at the Central Design Bureau by a team led by aircraft designer Nikolai Polikarpov. One of the world's first mass-produced monoplane fighters with retractable landing gear in flight. The aircraft had a mixed design. The serial production of the aircraft, originally with the M-22 engine, started in 1934, and really unfolded only the next year. In 1935, it became possible to install M-25 engines on the aircraft, which were a Soviet copy of the American Wright-Cyclone R-1820 F-3. The production of these engines was launched at the newly built aircraft factory No.19 in Perm. In 1935, using often American parts, the plant produced 660 M-25 engines. Some of these engines were intended for the I-16. In general, this aircraft was very reminiscent of the third prototype with the Wright-Cyclone R-1820 F-3.

The Finnish Air force took several damaged I-16 as trophies. One of the planes restored to flying condition, was a Type 5 that had previously served in the 11th Fighter Aviation Regiment of the Baltic Fleet Air Force and had been used as a ground attack aircraft, equipped with six rockets under its wings. In the Finnish Air Force, the aircraft served from August 1, 1942, to June 22, 1943, and later was placed in storage.

REQUIRED PAINTS



A.MIG-0230
MR. COLOR C121
OLIVE GREEN
FS34096



B.MIG-0046
MR. COLOR C92
BLACK



C.MIG-0241
MR. COLOR C1
LIGHT GRAY
FS36440



D.MIG-0048
MR. COLOR C329
YELLOW



F.MIG-0194
MR. COLOR C8
SILVER
ALUMINIUM



G.MIG-0191
MR. COLOR SM204
STEEL



J.MIG-0212
MR. COLOR C317
MEDIUM GRAY
A-14



K.MIG-0045
MR. COLOR C3
RED



L.MIG-0050
MR. COLOR C1
WHITE



M.MIG-0079
MR. COLOR C43
WOOD BROWN



N.MIG-0187
MR. COLOR C61
BURNT METALL



P.MIG-0033
MR. COLOR C137
TIRE BLACK



R.MIG-005
MR. COLOR C55
GREEN KHAKI



T.MIG-0093
MR. COLOR C47
RED CRYSTAL



U.MIG-0092
MR. COLOR C138
GREEN CRYSTAL



AMMO
by MIG Jimenez

THIS MODEL IS PRODUCED FOR EXPERIENCED MODELERS OVER 14 YEARS

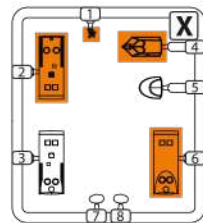
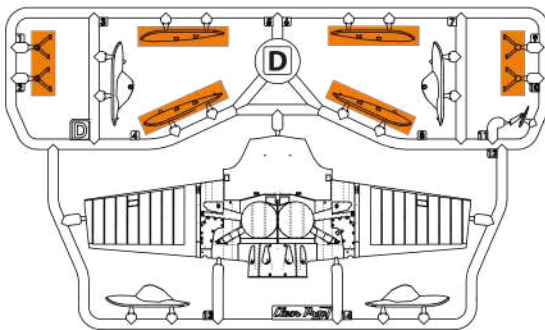
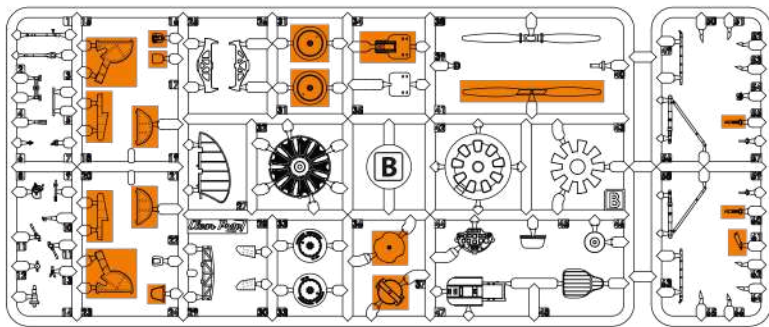
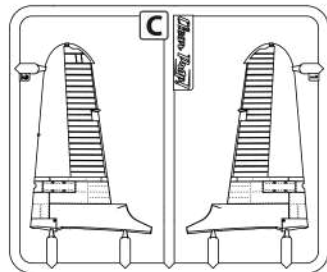
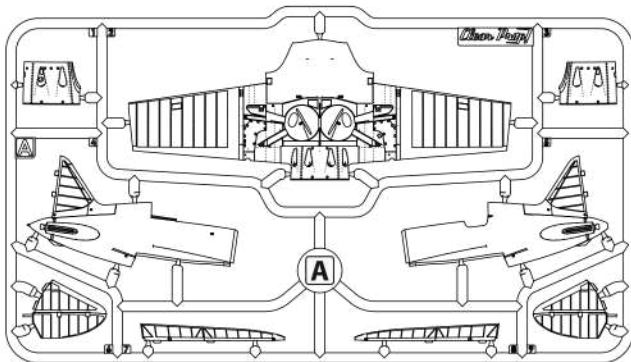

DECAL SHEET

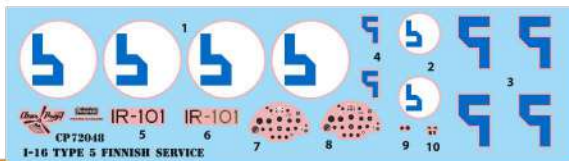

Parts not for use

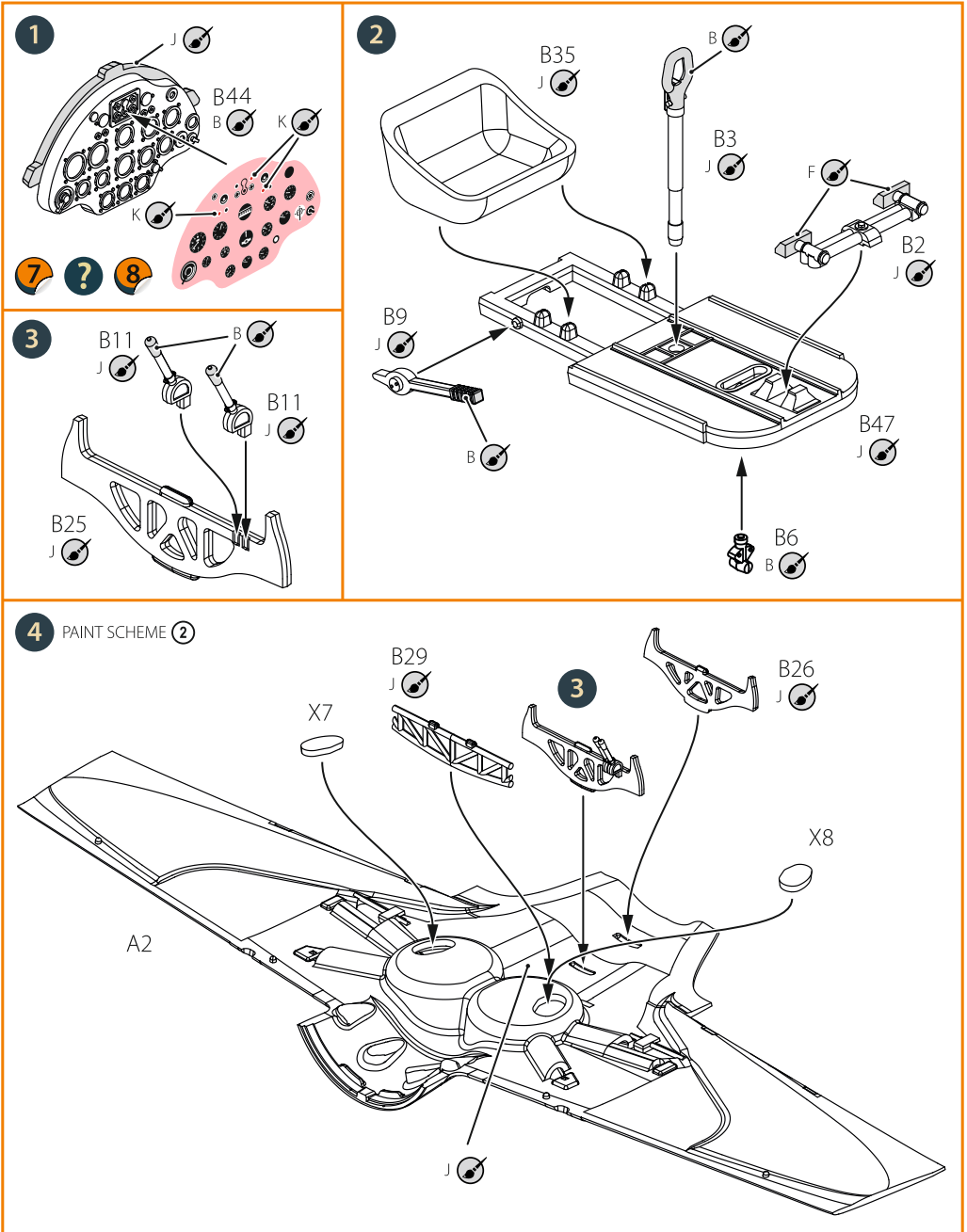

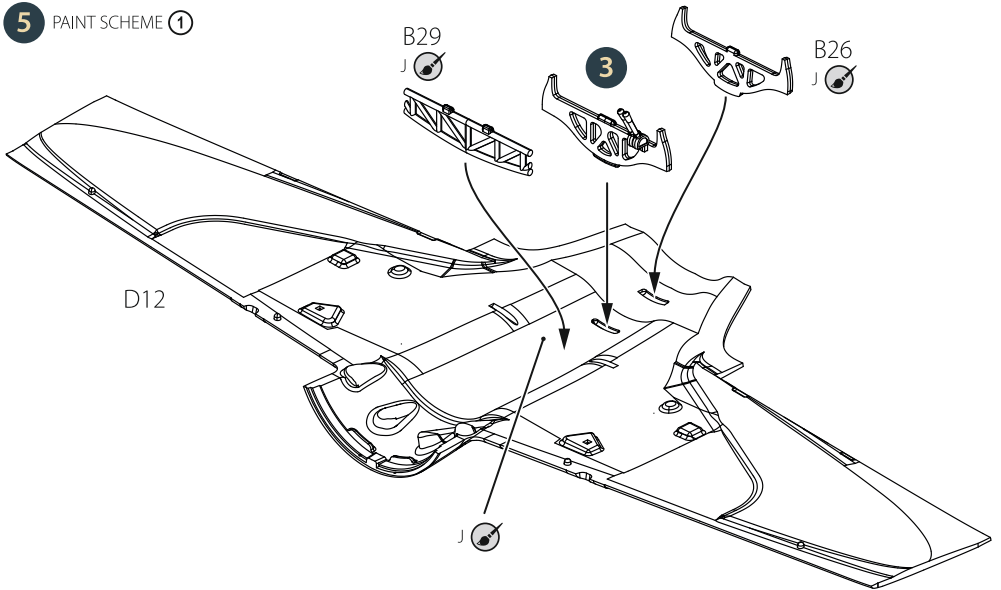
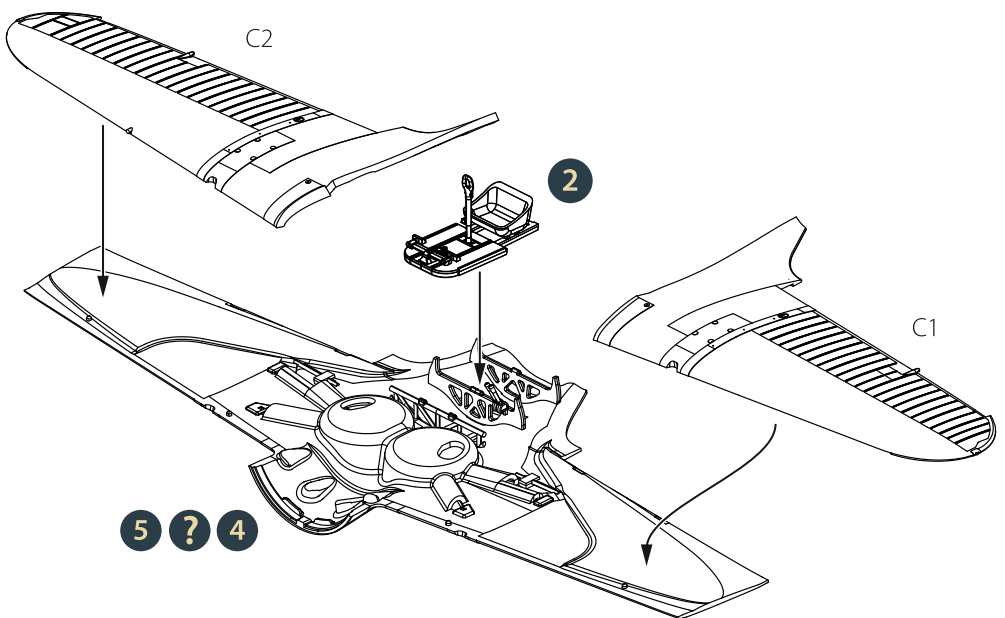
5 PAINT SCHEME ①**6**

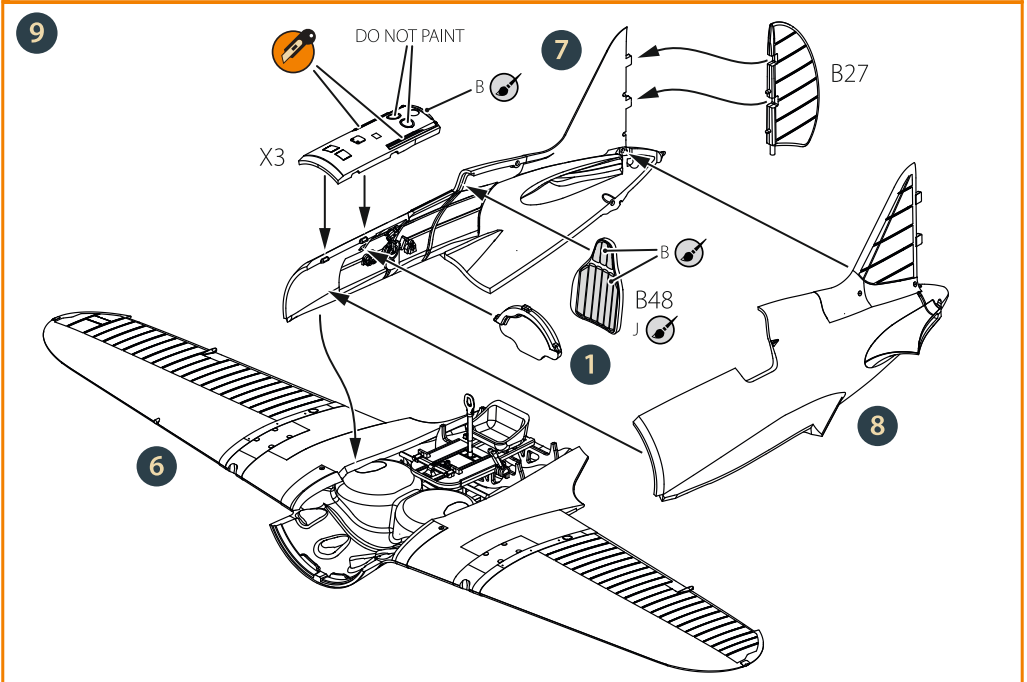
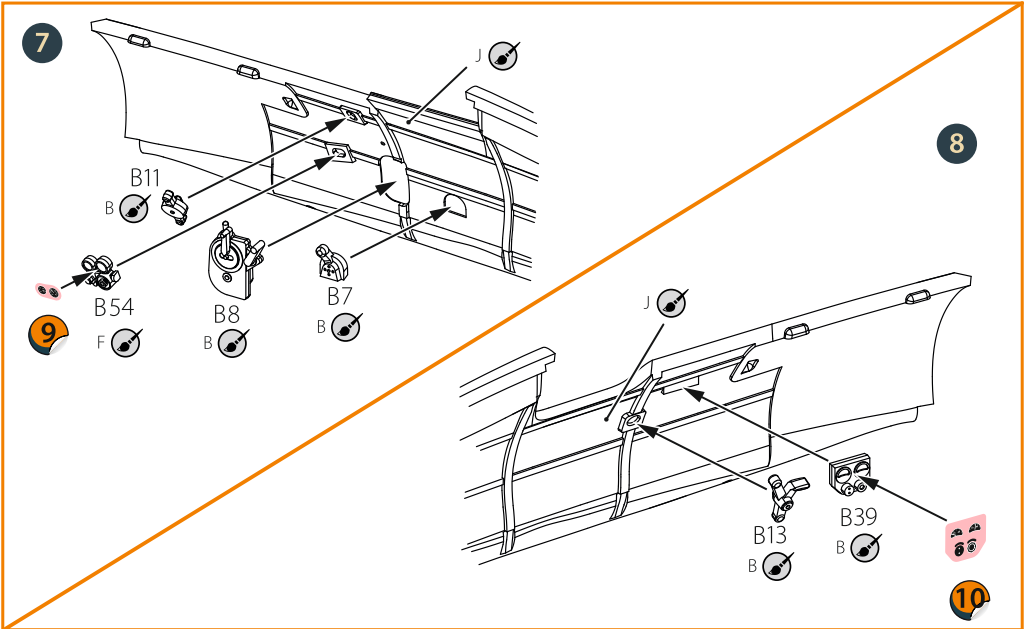

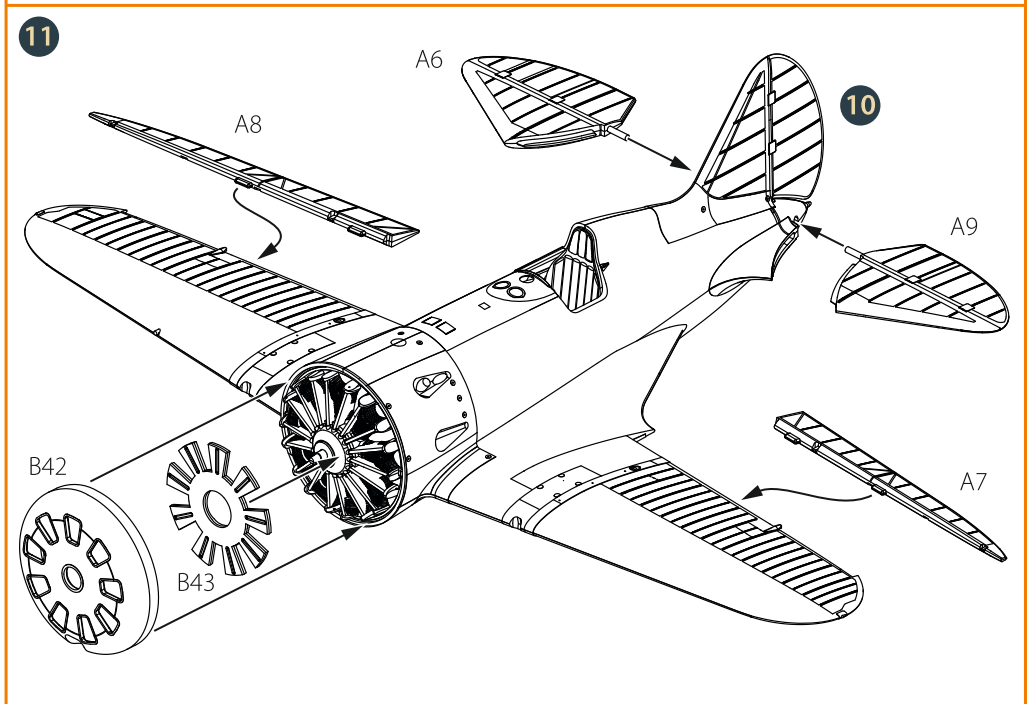
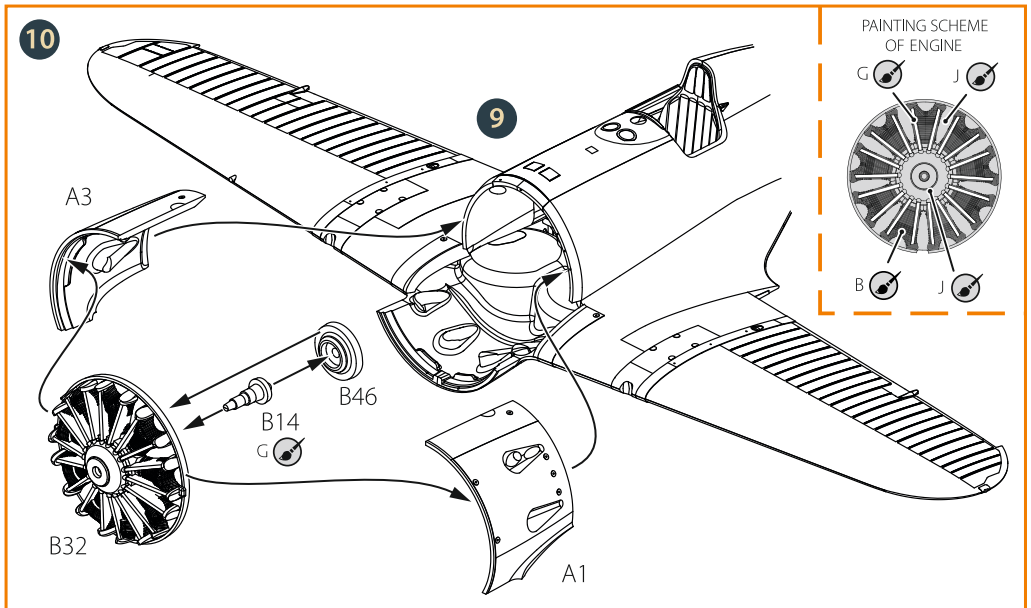

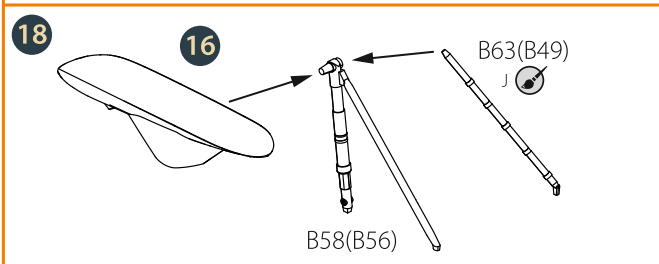
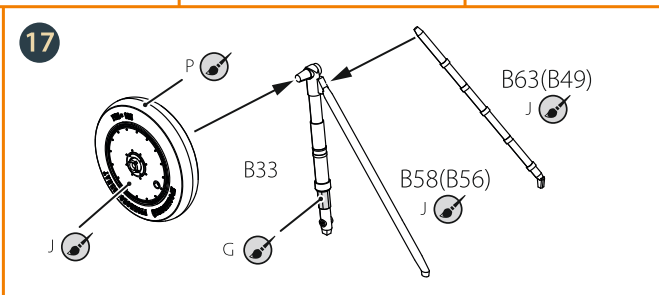
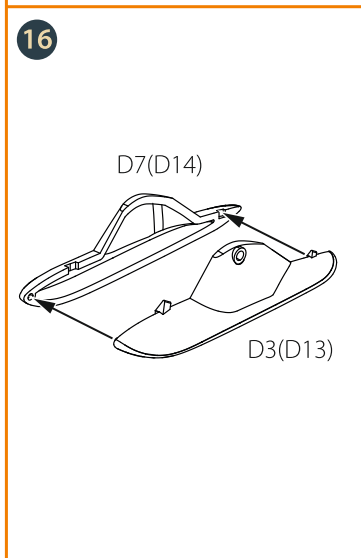
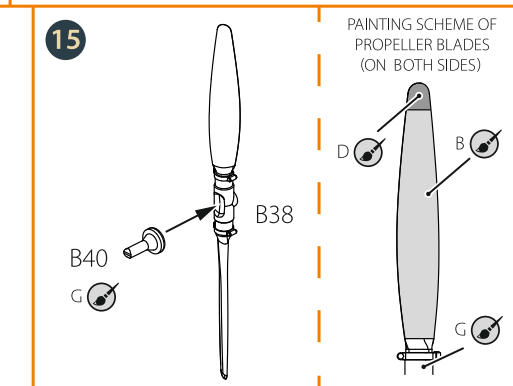
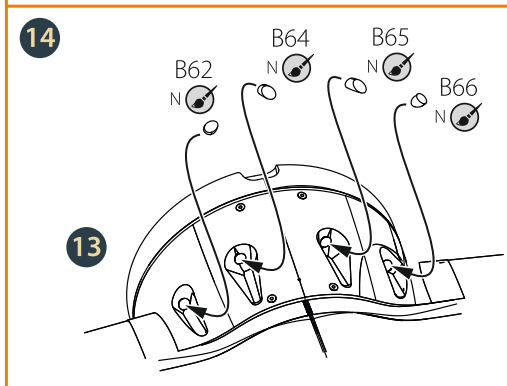
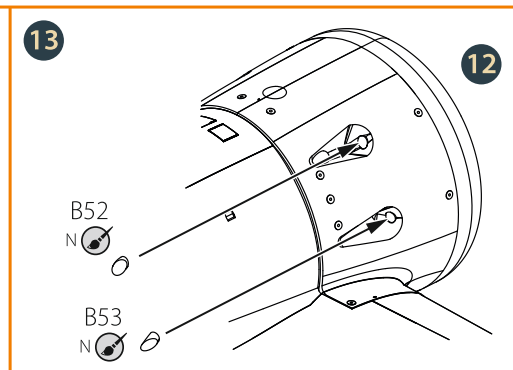
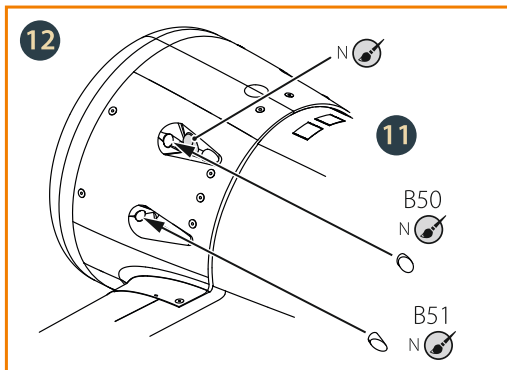

CORRECT POSITION OF SKI WIRES MAKE FROM SCRATCH

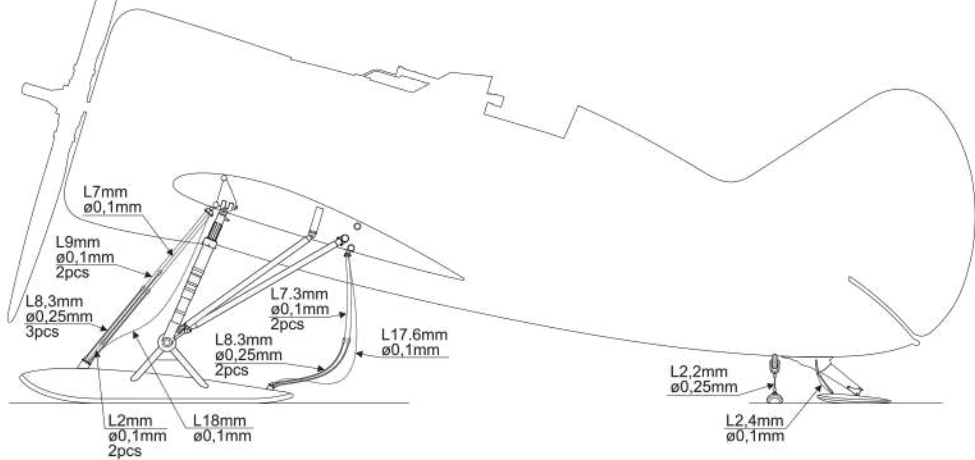

19 PAINT SCHEME (2)

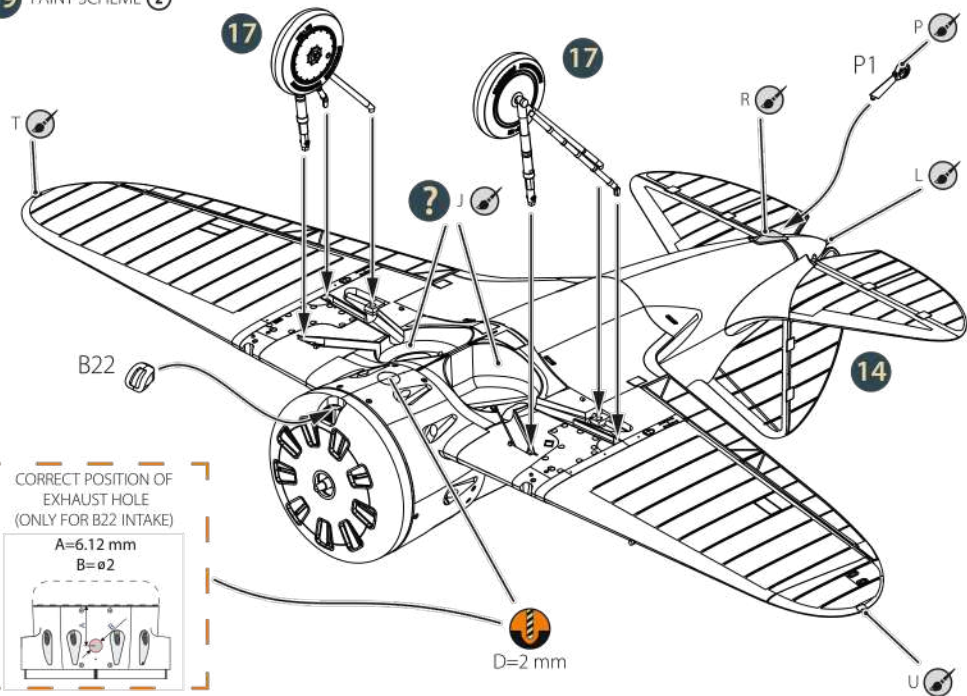

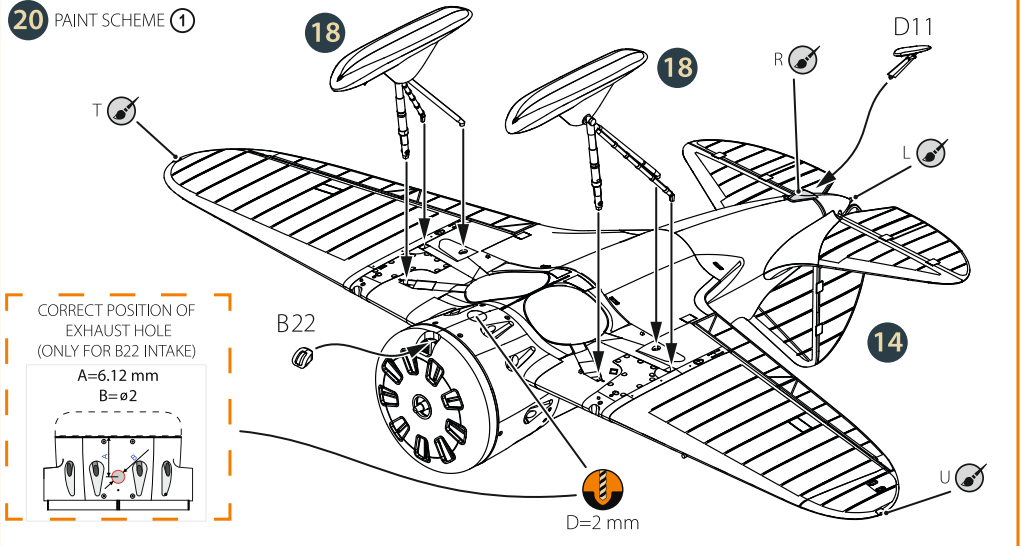
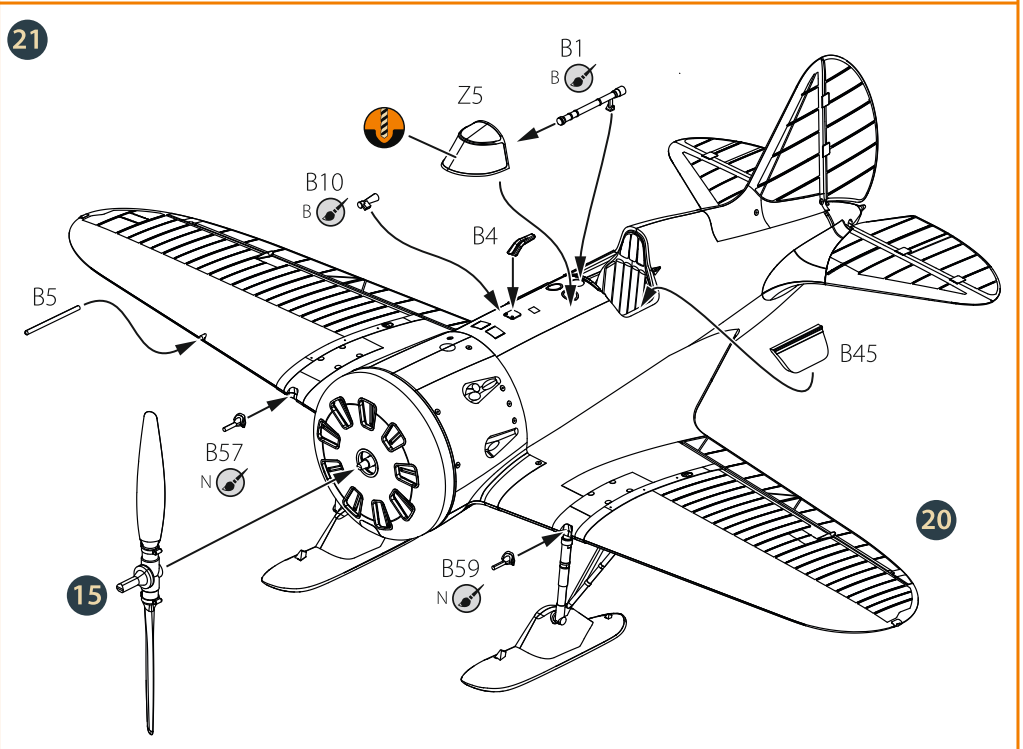
20 PAINT SCHEME ①

21



A.MIG-0230
MR. COLOR C121
OLIVE GREEN
FS34096



A.MIG-0046
MR. COLOR C92
BLACK



A.MIG-0241
MR. COLOR C1
LIGHT GRAY
FS36440



A.MIG-0048
MR. COLOR C329
YELLOW



A.MIG-0191
MR. COLOR SM204
STEEL



A.MIG-0079
MR. COLOR C43
WOOD BROWN

① I-16 type 5, in service with 2/LeLv 30 of the Finnish Air Force, winter 1942-1943.

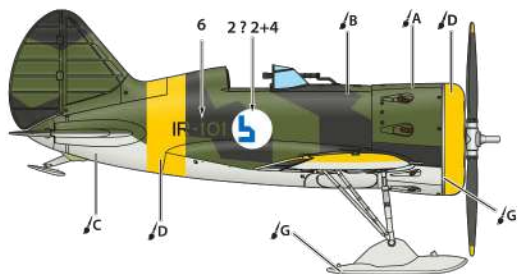
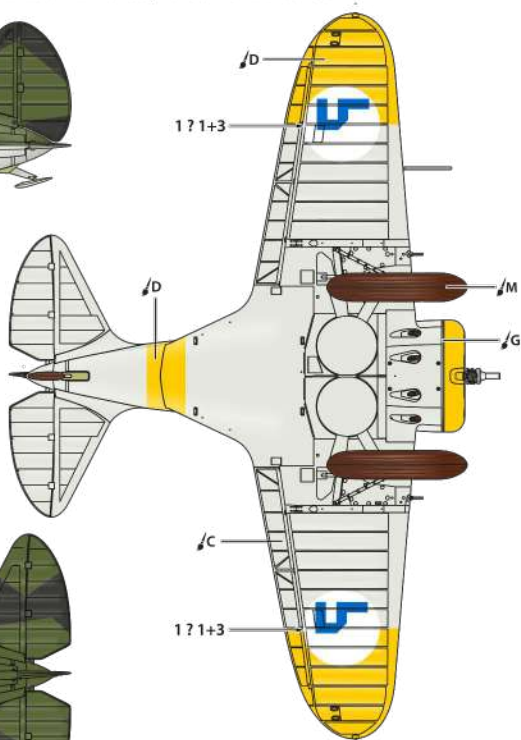
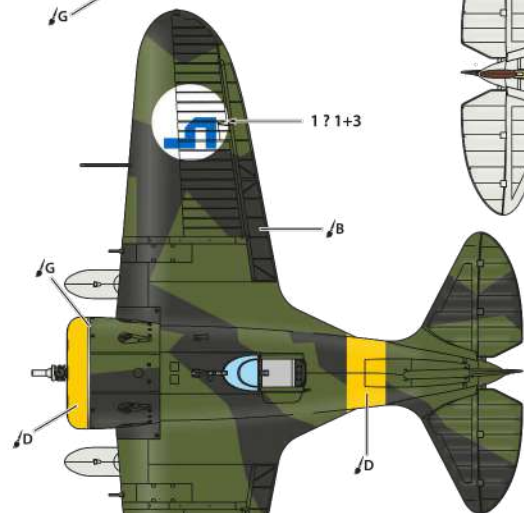
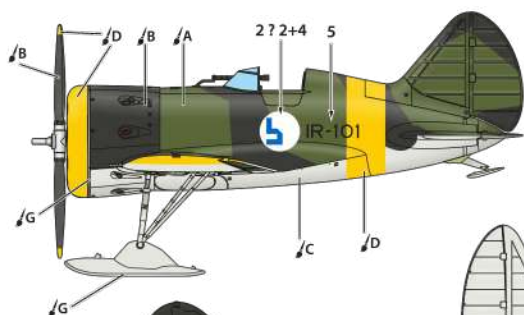



A
A.MIG-0230
MR. COLOR C121
OLIVE GREEN
FS34096



B
A.MIG-0046
MR. COLOR C92
BLACK



C
A.MIG-0241
MR. COLOR C1
LIGHT GRAY
FS36440



D
A.MIG-0048
MR. COLOR C329
YELLOW



G
A.MIG-0191
MR. COLOR SM204
STEEL

② I-16 type 5, in service with 3/LeLv 6 of the Finnish Air Force, August 1942.

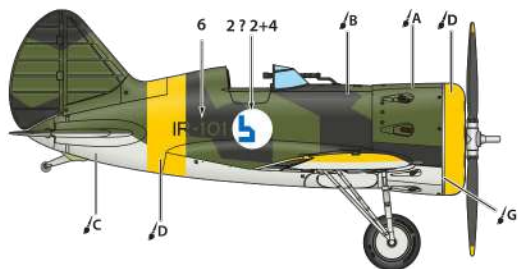
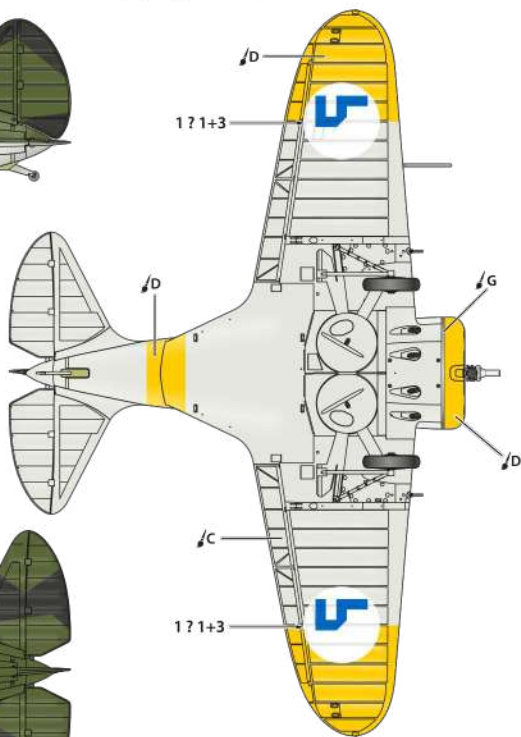
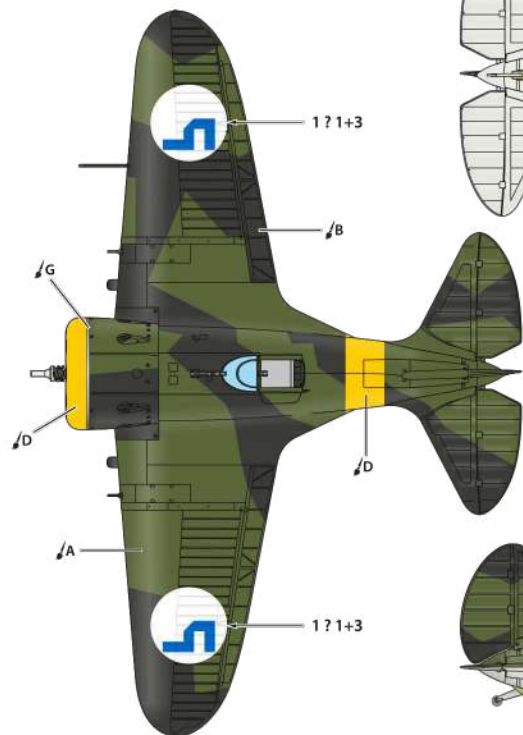
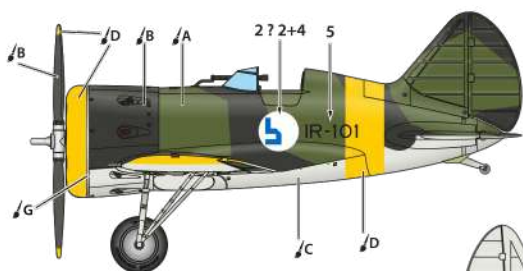



VISIT OUR SITE FOR MORE SCALE MODEL KITS
clearpropmodels.com



sales@clearpropmodels.com



[www.fb.com/Clearpropmodels](https://www.facebook.com/Clearpropmodels)