

Diamond T 968 Cargo Truck - Softcab with M2 Machine Gun



Cat. No. 72084
Scale 1/72

3d design: Przemysław Głogowski
Research: IBG Crew



Photo-etched Parts / Elementy Fototrawione

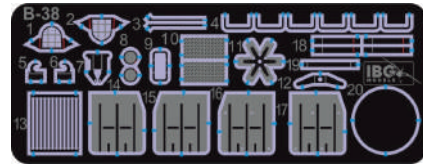

Element assembled in previous step
Element złożony we wcześniejszym etapie



Element after assembly in current step
Element po złożeniu w aktualnym etapie



Paint colour
Kolor farby



Decal
Kalkomania



Version to choose
Wersja do wyboru

Clear Film / Klisza

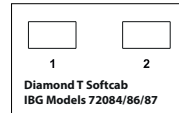

Decals / Kalkomanie



Frame F / Ramka F

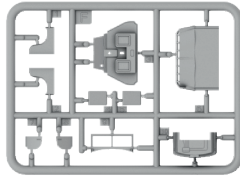

Ramka Q / Frame Q

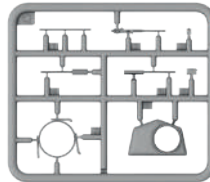

Ramka C / Frame C

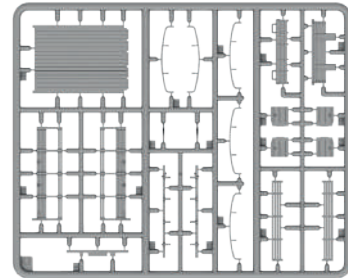

Frame A1 / Ramka A1

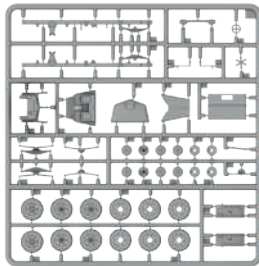

Frame A2 / Ramka A2

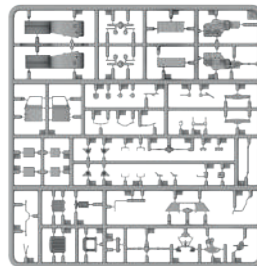

Frame H / Ramka H

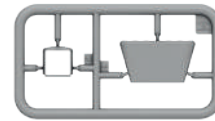

		VALLEJO MODEL AIR	HATAKA	LIFE COLOR	MR HOBBY	AK INTERACTIVE	MISSION MODELS
Black	A	71.315	HTK-_100	UA733	H077	RC022	MMP-040
Rust	B	71.080	HTK-_132	LC32	H47	AK708	MMW-001
US Olive Drab	C	71.043	HTK-_065	UA523	H304	RC026	MMP-021
Canvas	D	71.326	HTK-_234	UA214	H70	RC293	MMP-023
Gunmetal	E	71.072	HTK-_106	LC26	H018	RC015	MMM-010

Please follow the steps of the instructions strictly. Glue and paint not included.

Proszę postępować ściśle według etapów instrukcji. Klej i farby nie wchodzą w skład zestawu.

IBG Models
ul. Benedykta Hertza 2
04-603 Warszawa
Poland

tel +48 22 8159150
fax +48 22 8159151
ibgsc@ibg.com.pl
www.ibg.com.pl
www.ibgmodels.com

Step 1
Etap 1

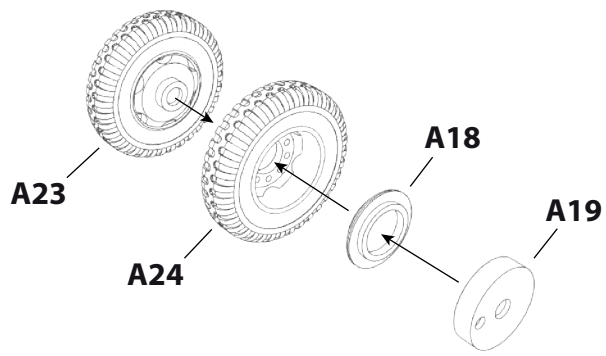

Make 4
Wykonaj 4

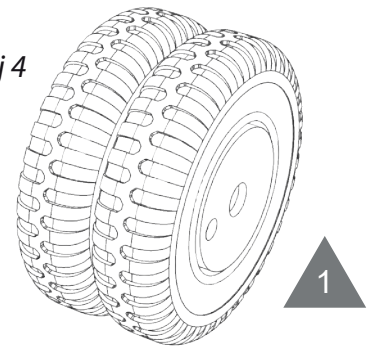

Step 2
Etap 2

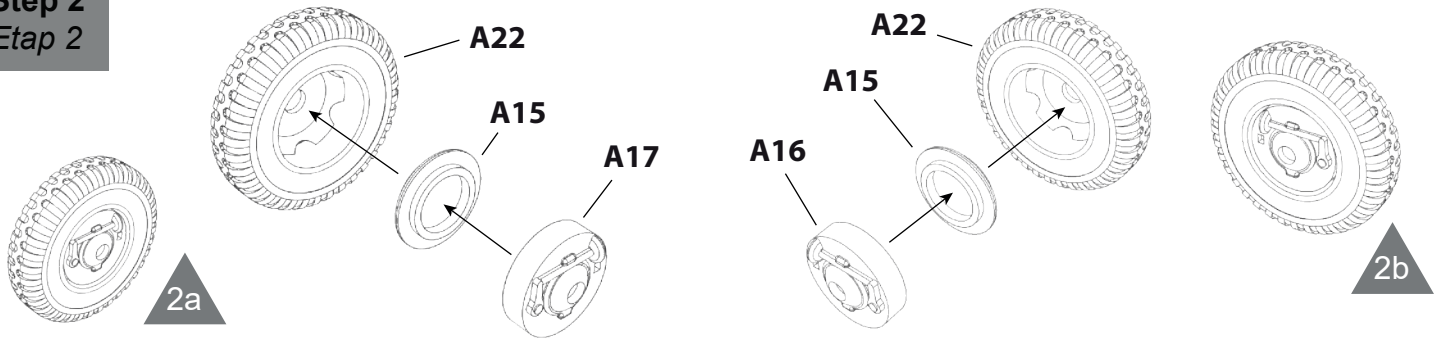

Step 3
Etap 3

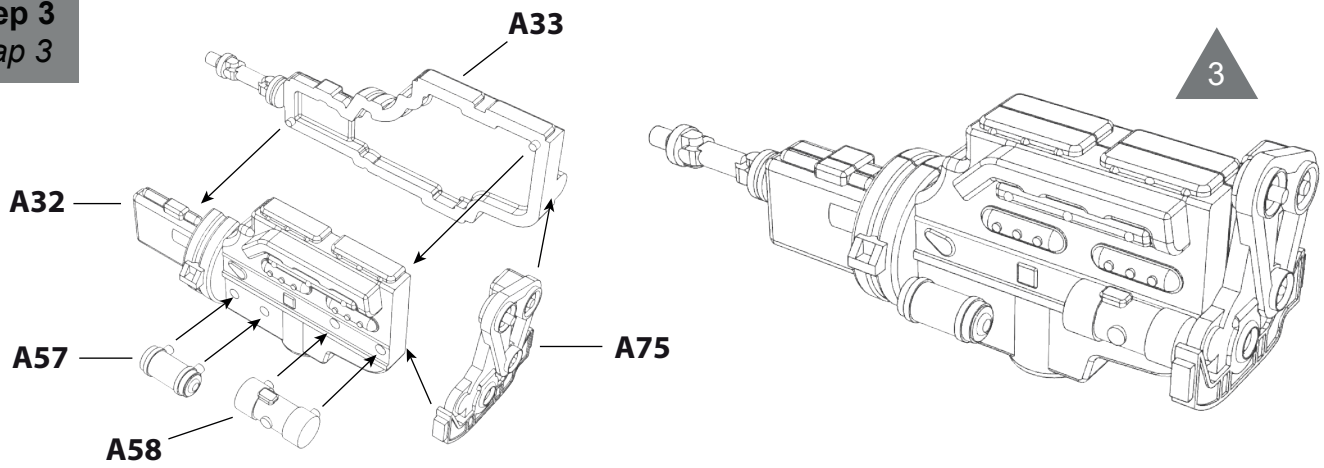

Step 4
Etap 4

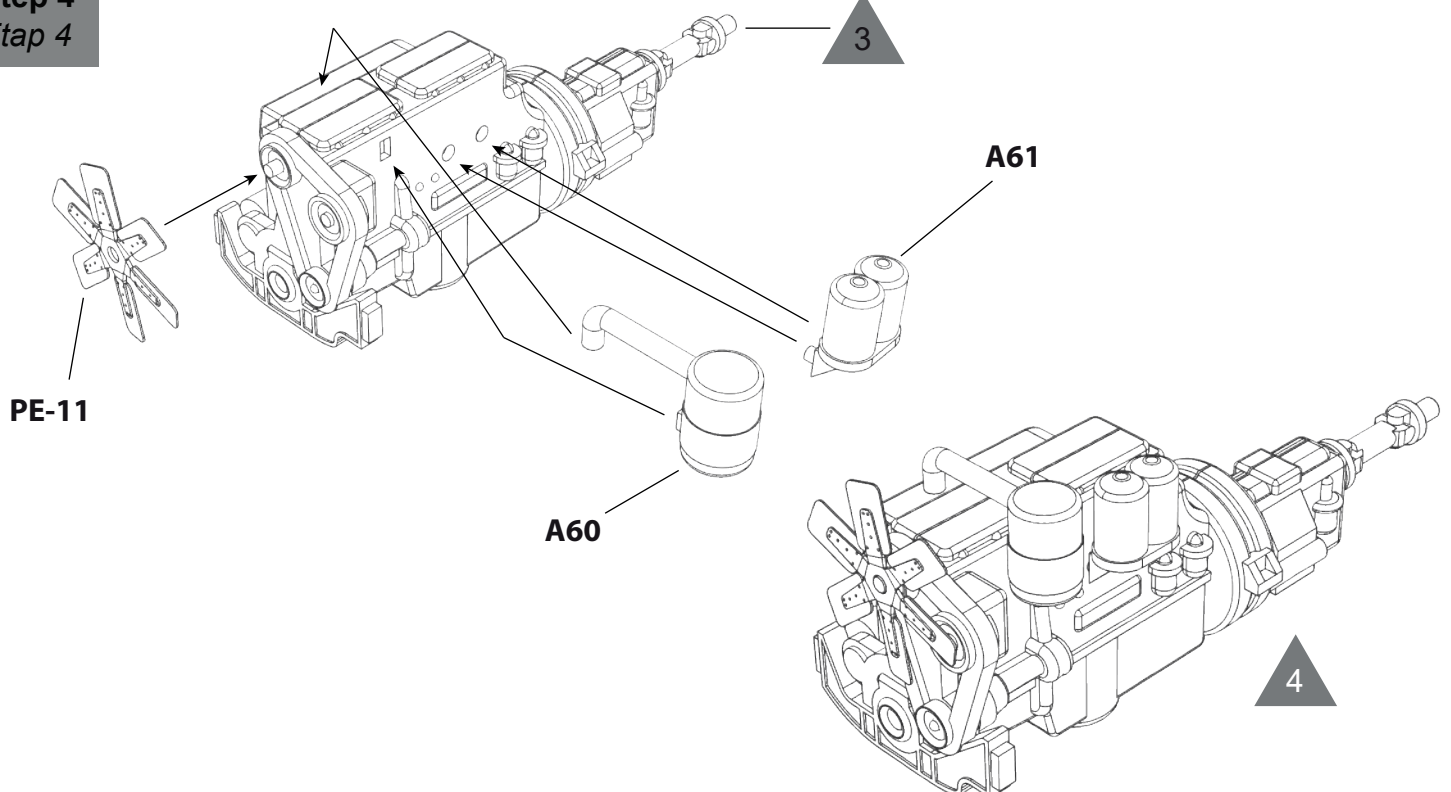

Step 5
Etap 5

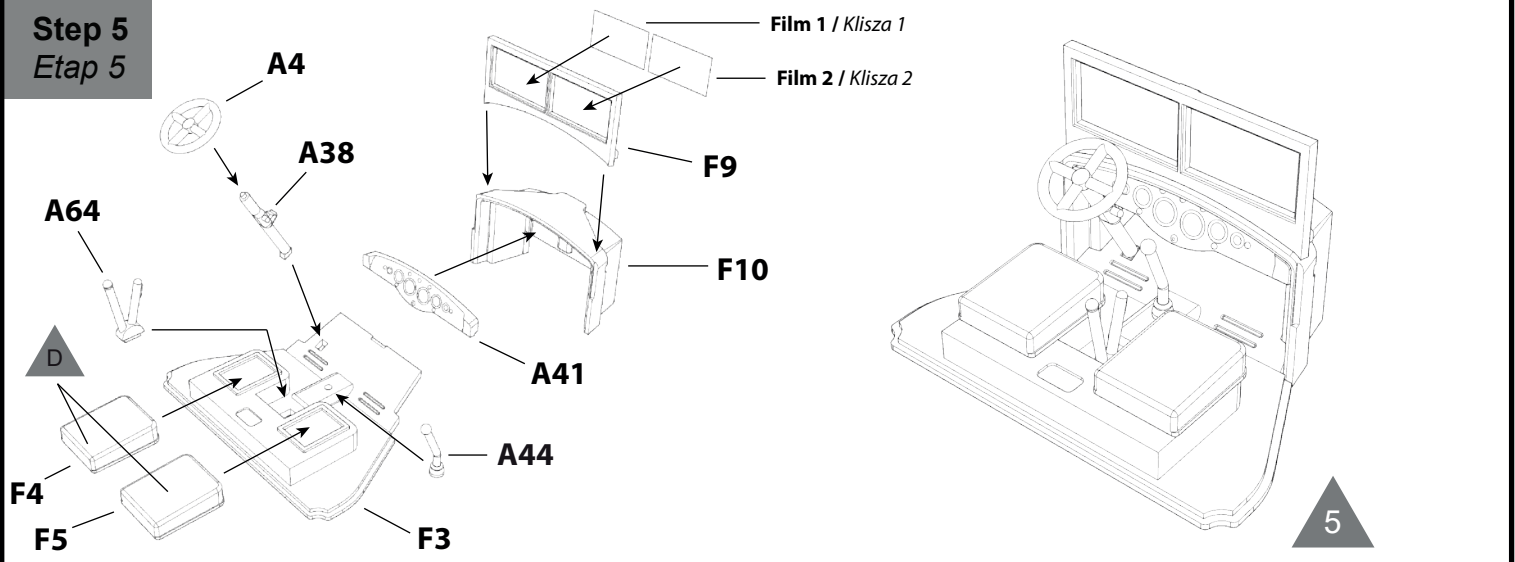

Step 6
Etap 6

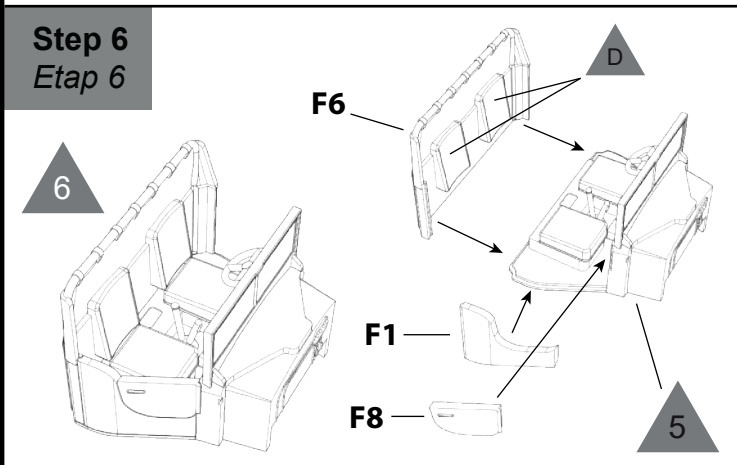

Step 7
Etap 7

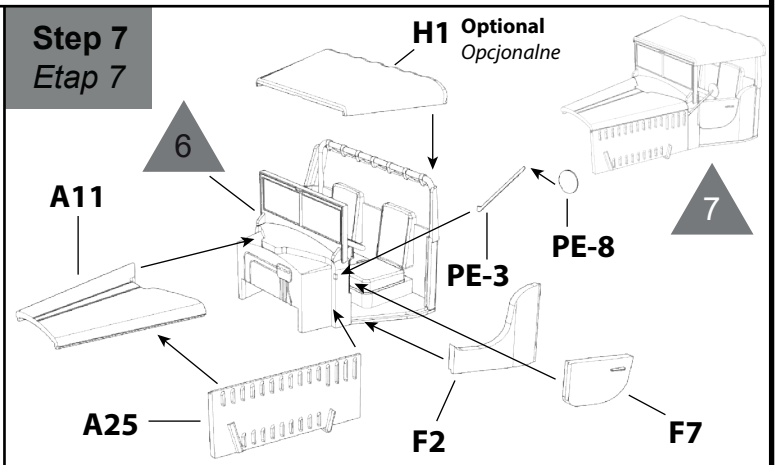

Step 8
Etap 8

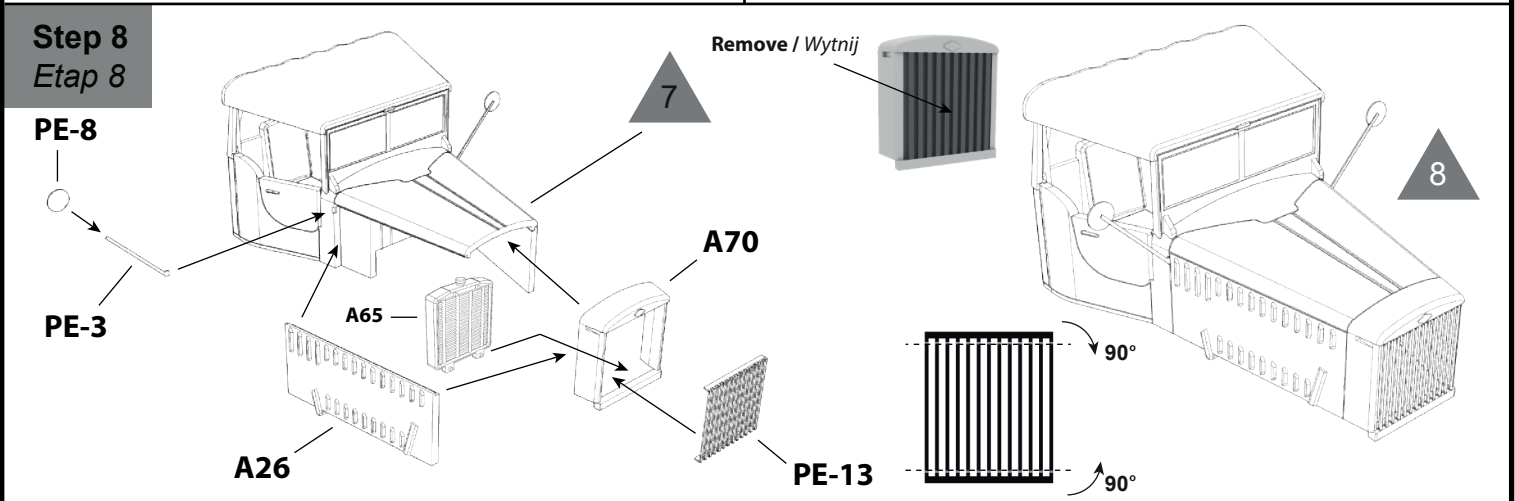

Step 9
Etap 9

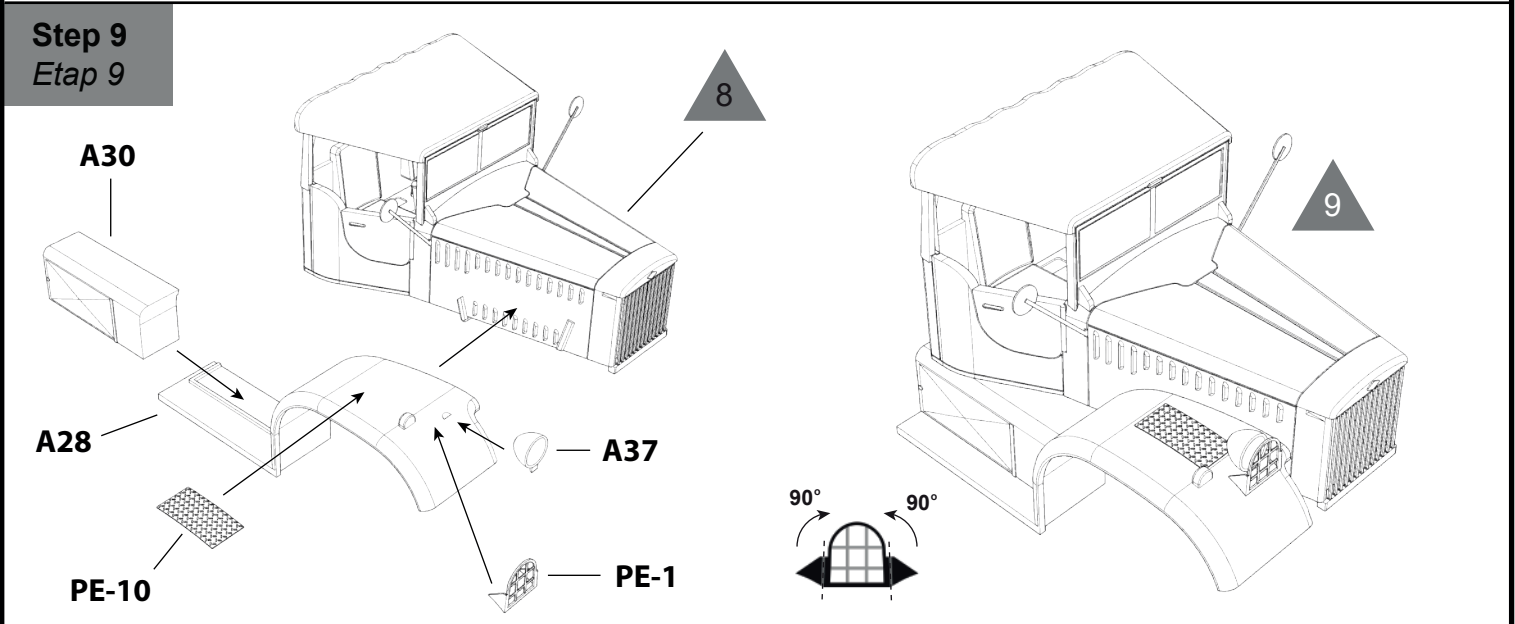

Step 10
Etap 10

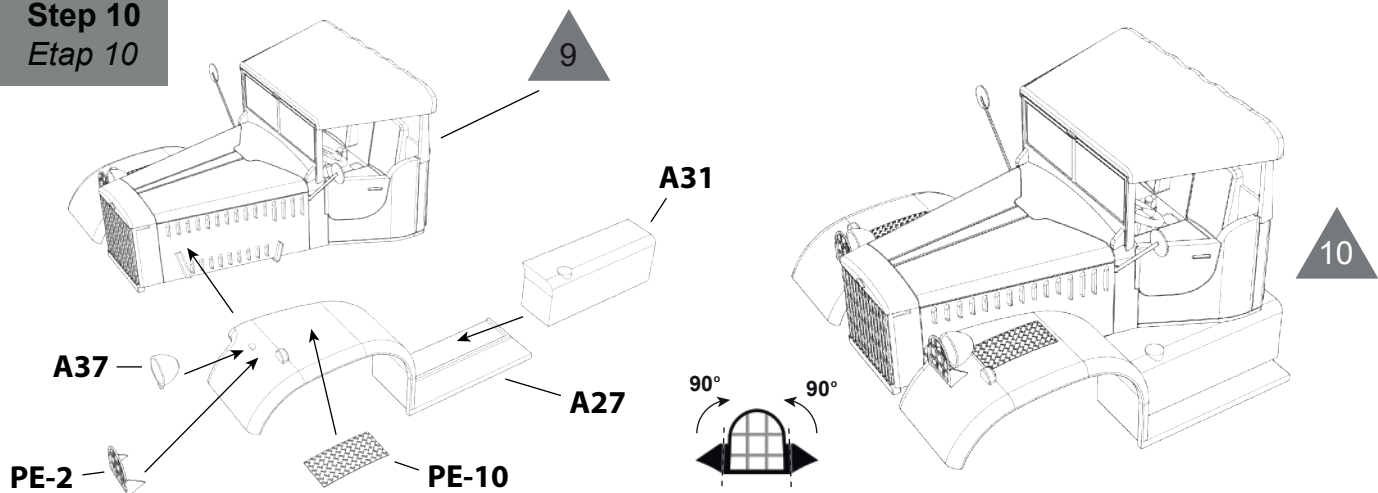

Step 11
Etap 11

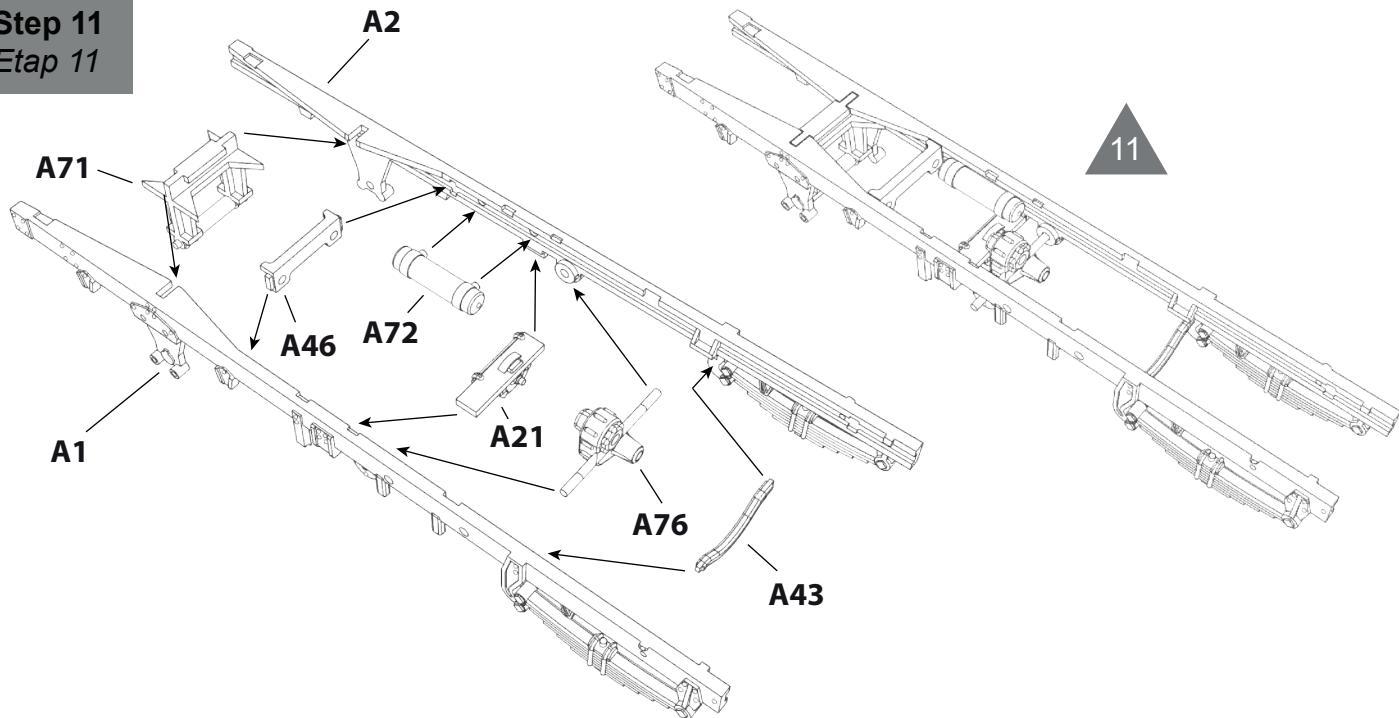

Step 12
Etap 12

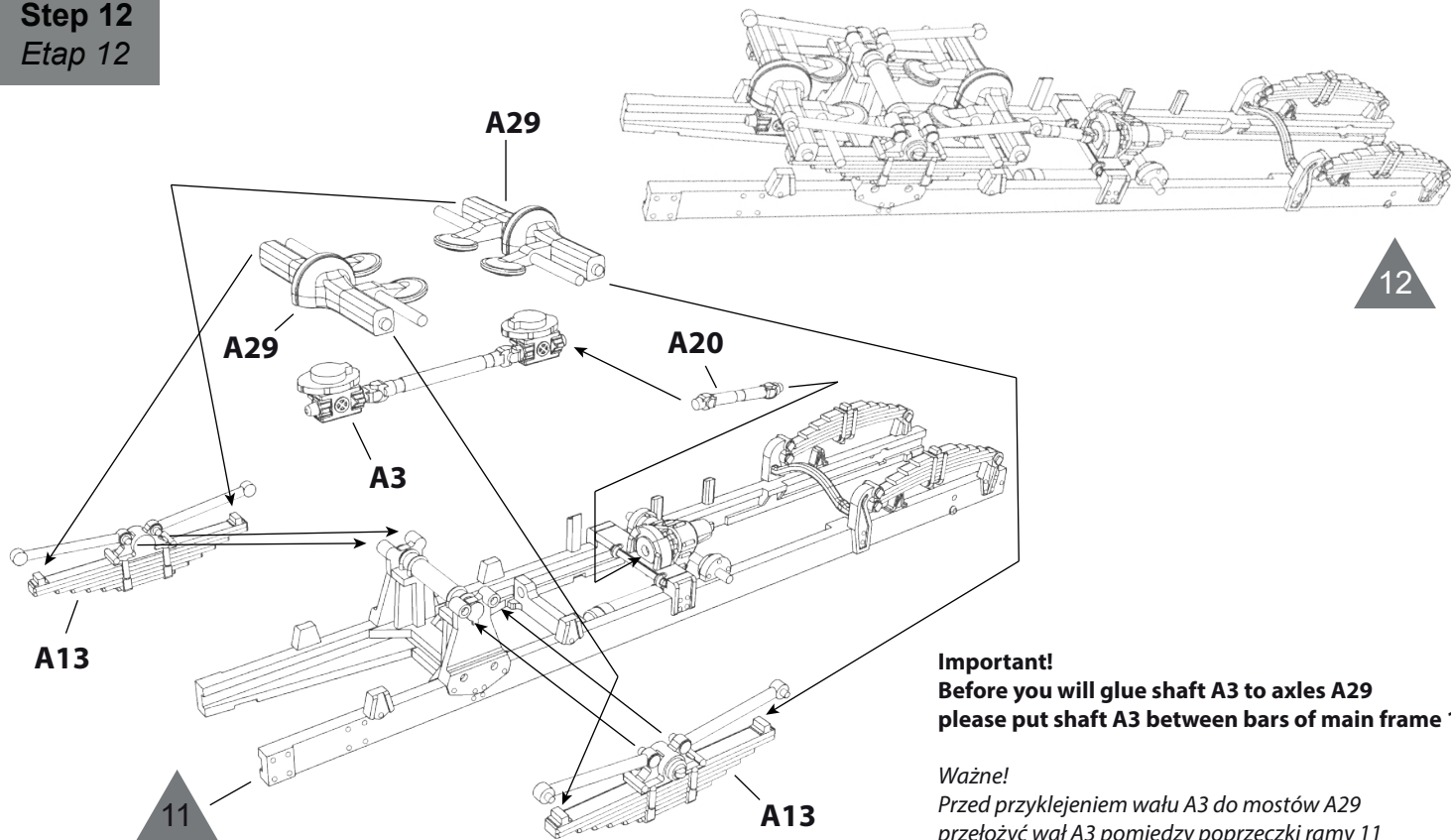

Important!
Before you will glue shaft A3 to axles A29
please put shaft A3 between bars of main frame 11

Ważne!
Przed przyklejeniem wału A3 do mostów A29
przełożyć wał A3 pomiędzy poprzeczki ramy 11

Step 13
Etap 13

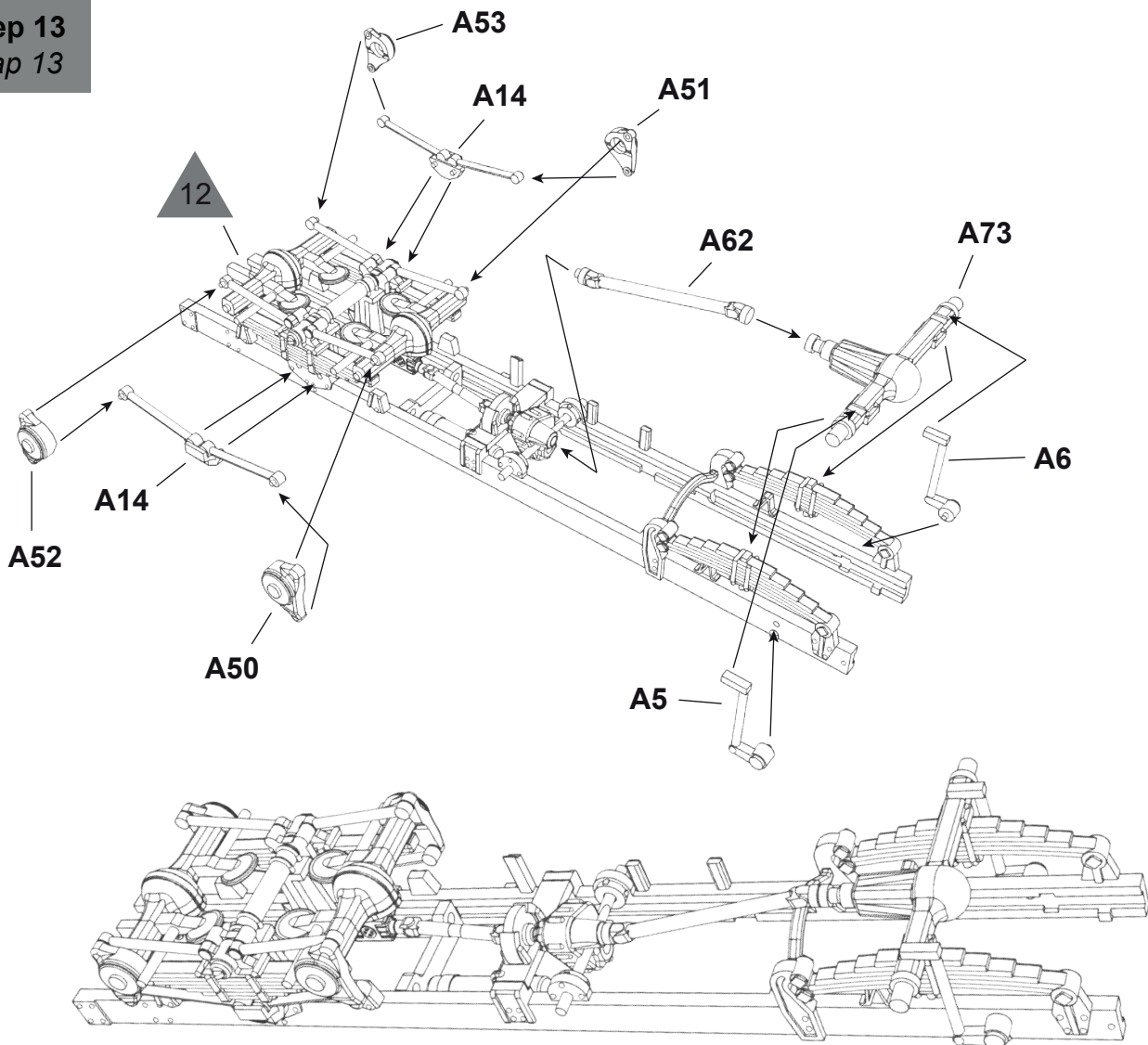

Step 14
Etap 14

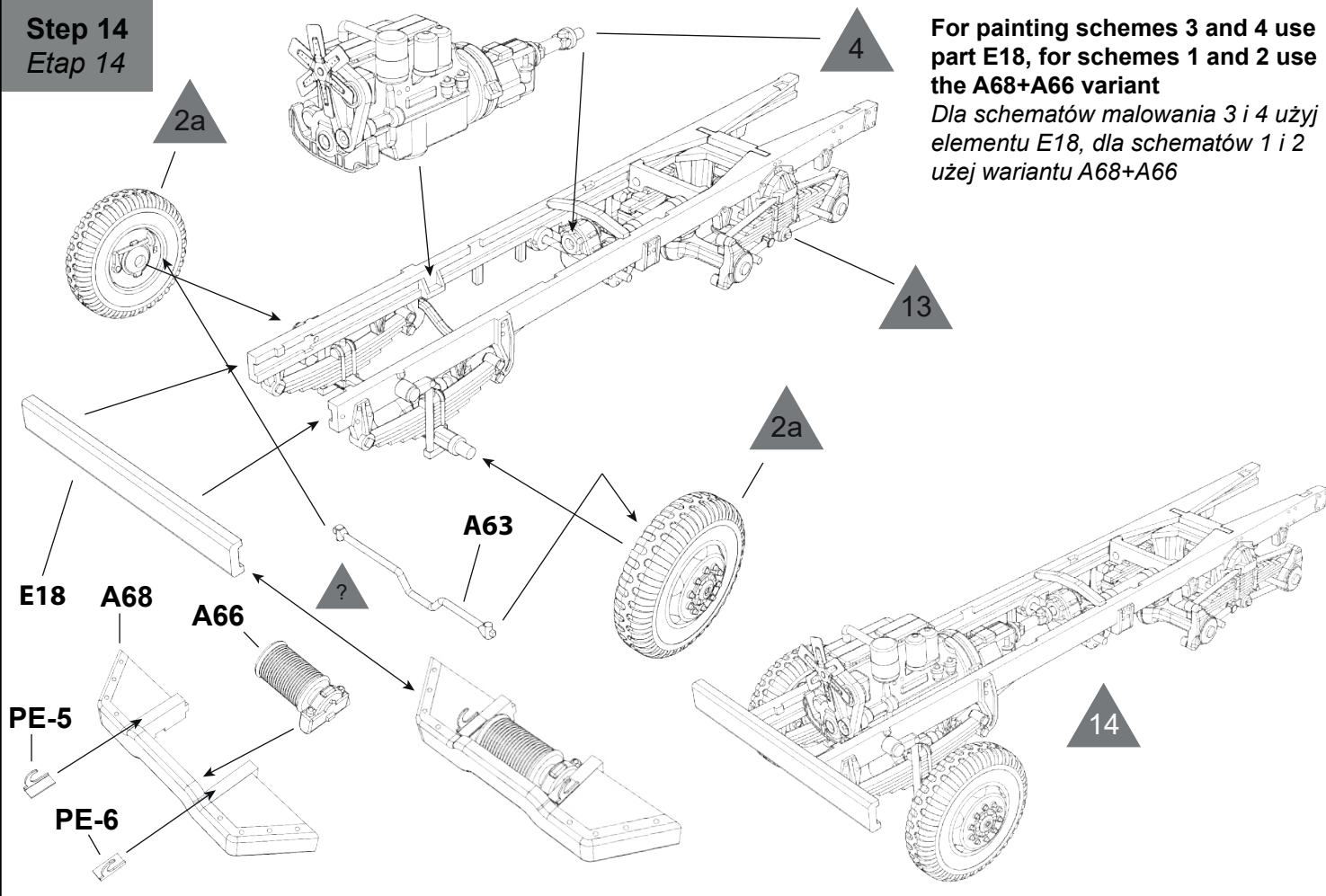

For painting schemes 3 and 4 use part E18, for schemes 1 and 2 use the A68+A66 variant
Dla schematów malowania 3 i 4 użyj elementu E18, dla schematów 1 i 2 użyj wariantu A68+A66

Step 15
Etap 15

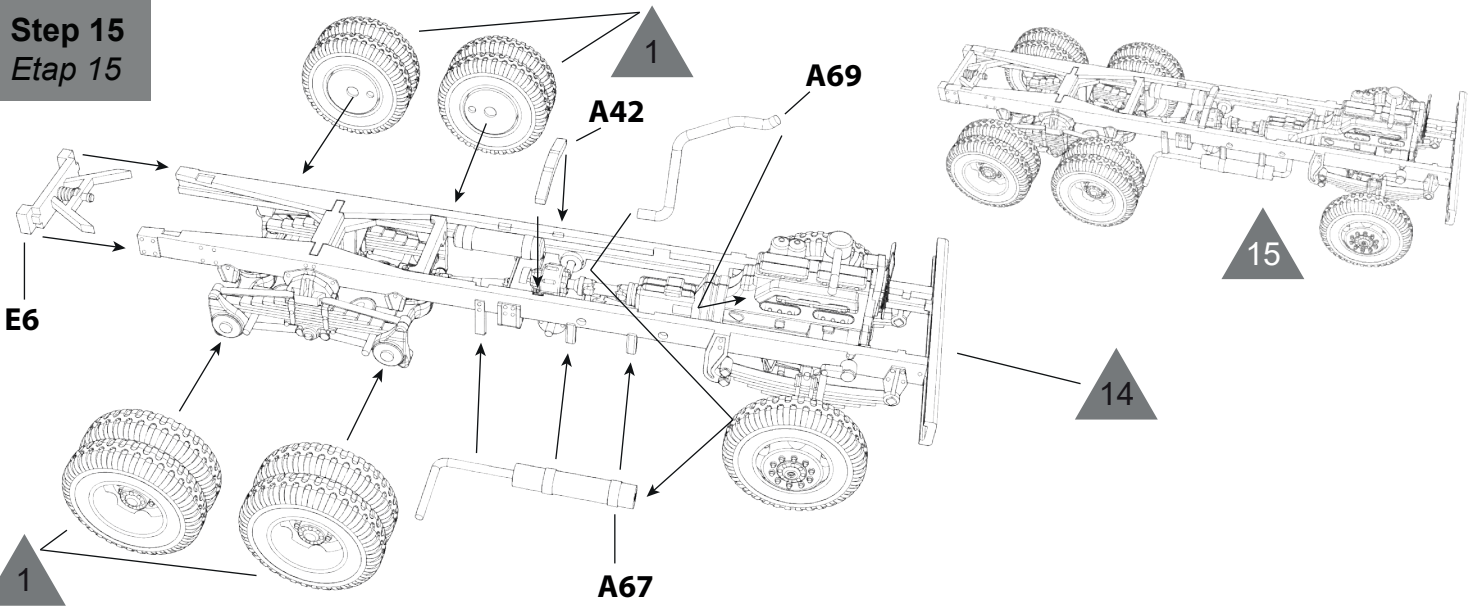

Step 16
Etap 16

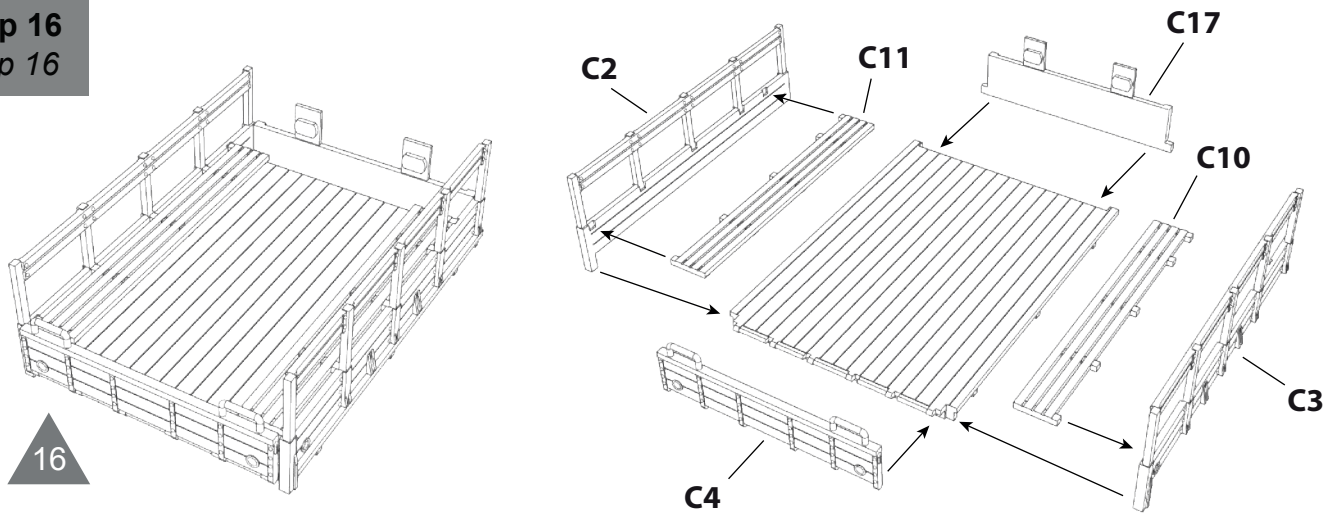

Step 17
Etap 17

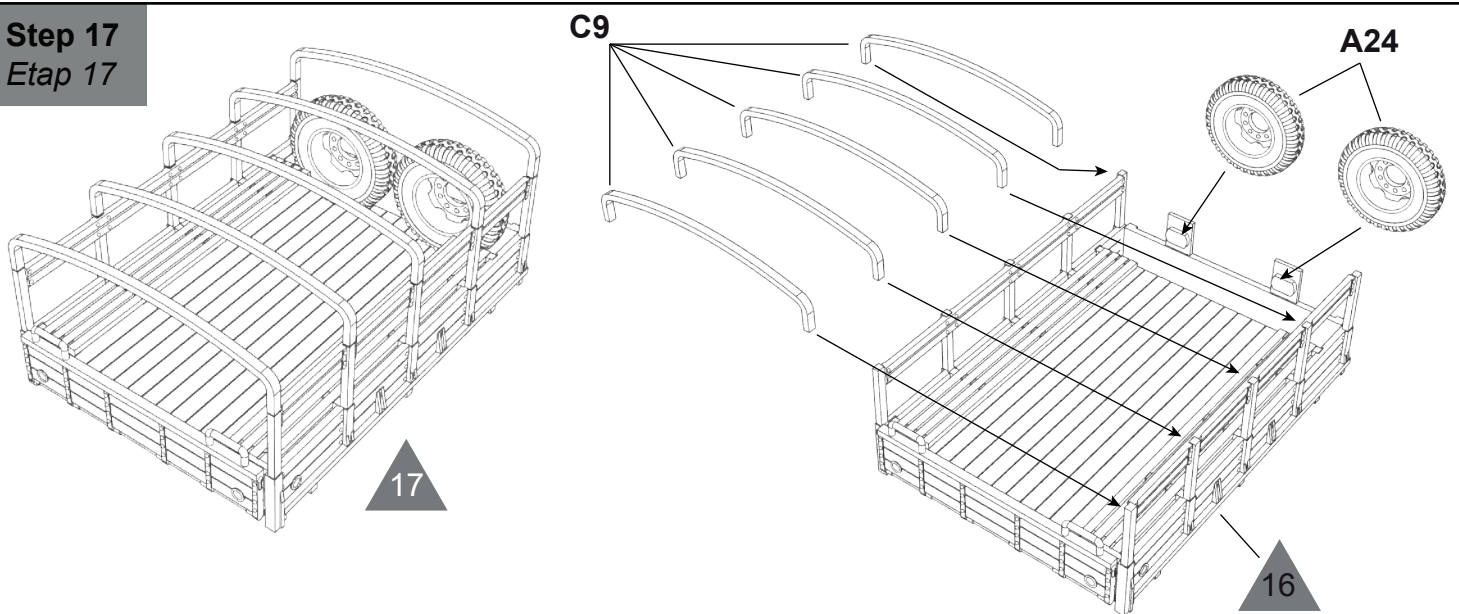

Step 18
Etap 18

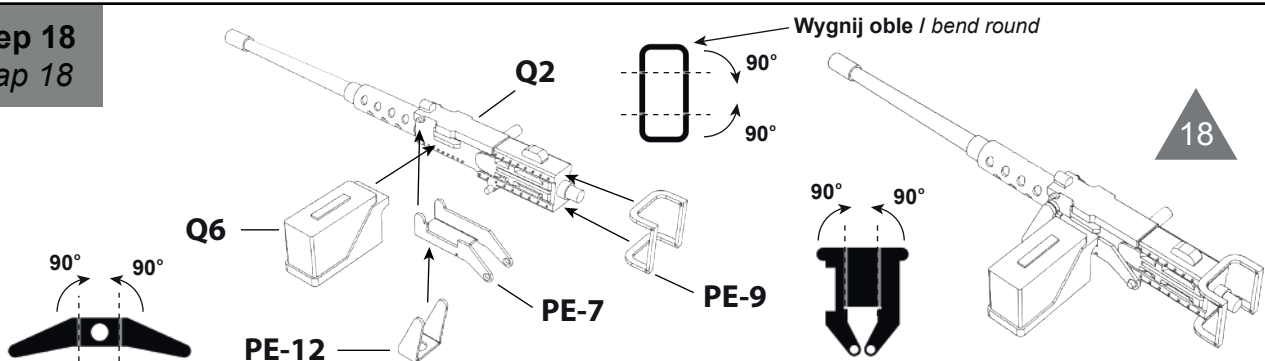

Step 19
Etap 19

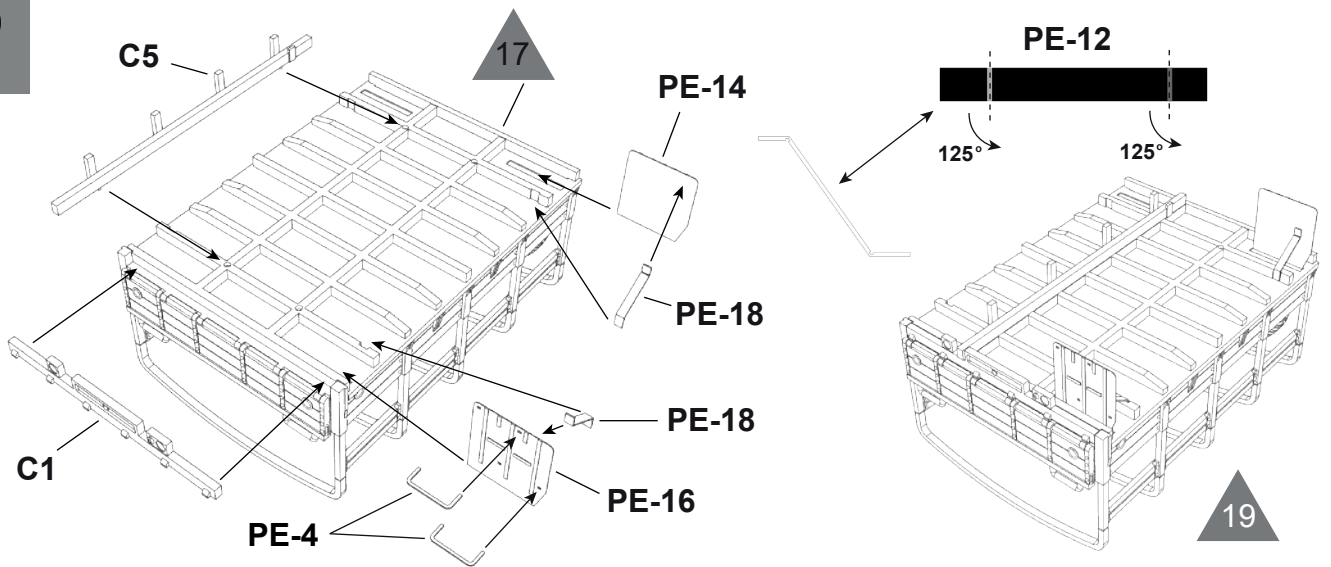

Step 20
Etap 20

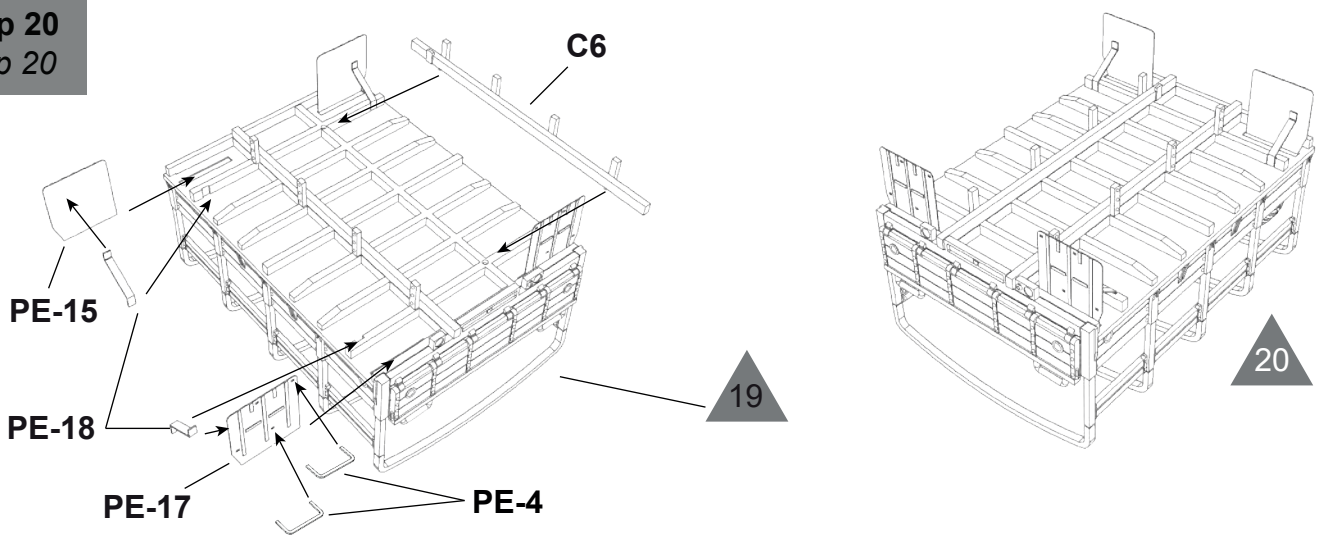

Step 21
Etap 21

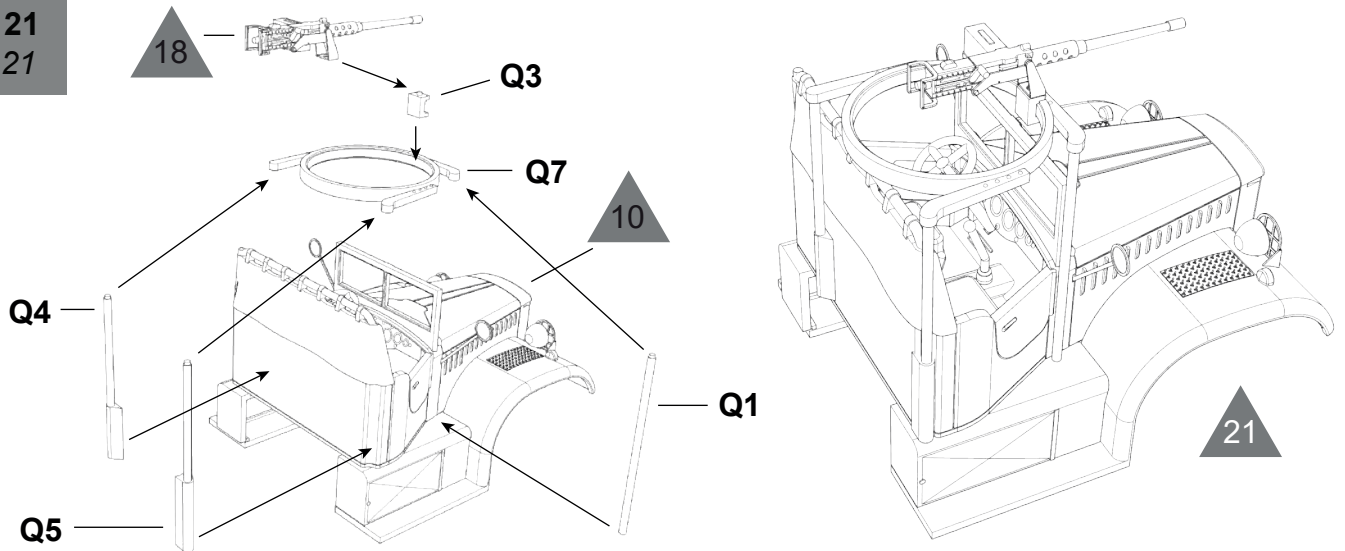

Step 22
Etap 22

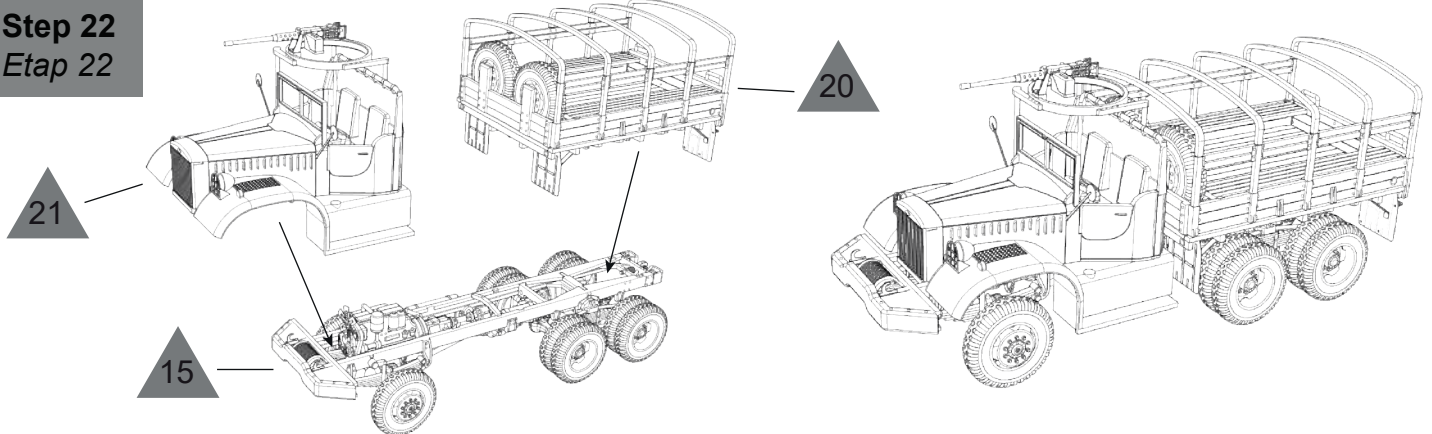

1

Diamond T 968, 2nd Armoured Division, 17 Engineers Battalion, 10th Vehicle of HQ Company, 1944-45
Diamond T 968, 10. wóz kompanii dowodzenia z 17 batalionu inż/saperów 2-giej Dywizji Pancerniej, 1944-45 r.

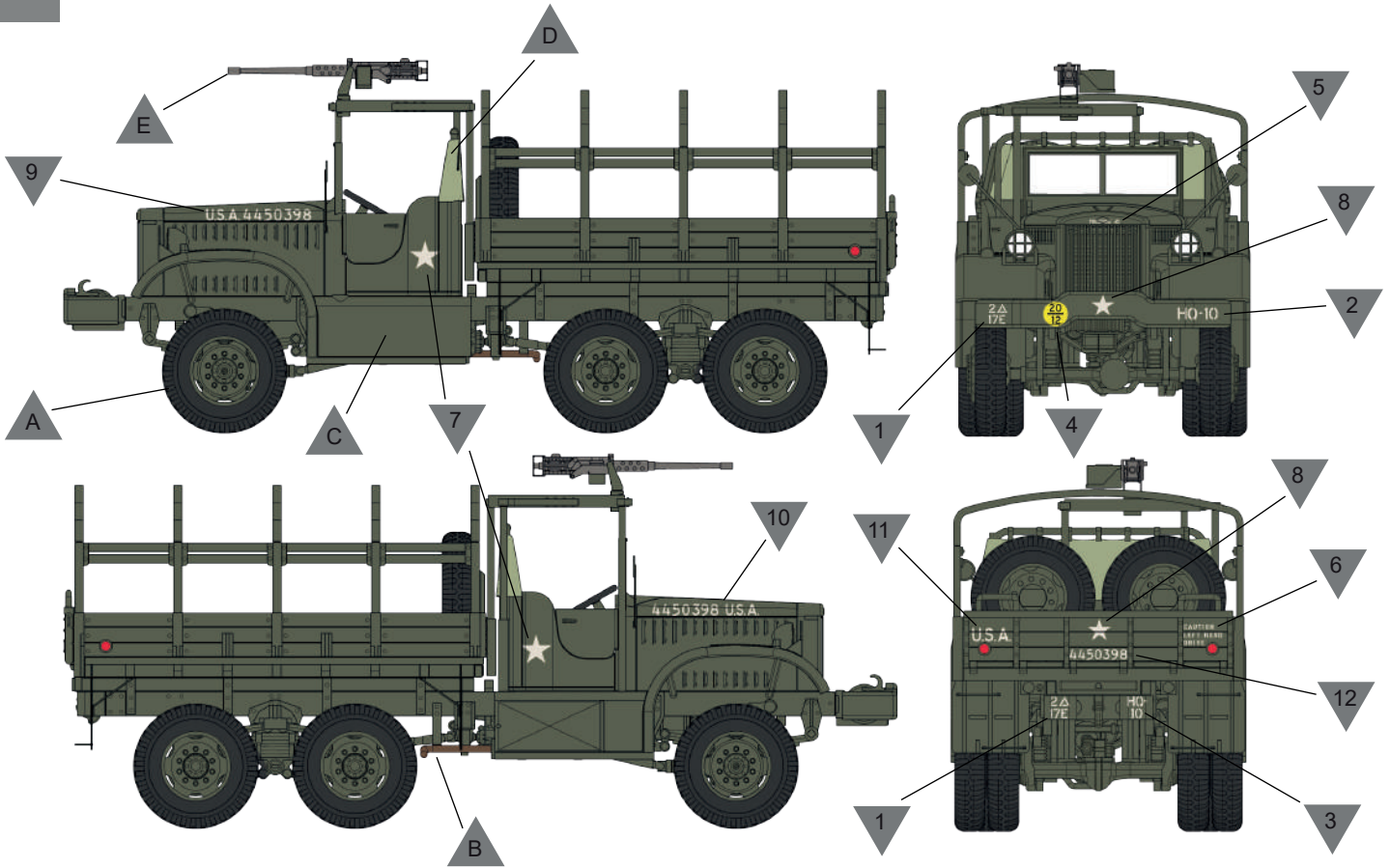

2

Diamond T 968, unknown unit, US Army
Diamond T 968, nieznaną oddział, US Army

