

# Spitfire Mk.IXc

eduard

1/72 Scale Plastic Model Kit

**WEEKEND**  
edition



item # 7466

The Spitfire is so iconic, that virtually everyone can recognize it. The life of this elegant fighter spanned remarkable 13 years. It entered into service at the end of biplane era and remained on frontline duty use until the jet age.

By the early 30s the RAF was looking for replacement of its ageing Hawker Fury biplane fighters. The need of considerably faster aircraft was obvious, as the racing monoplane floatplanes of that time reached about twice the speed of the Fury. One of the most successful designers of racing floatplanes was Reginald J. Mitchell. His Supermarine S.6B raised the world speed record to 407 mph (655 km/h) on 20 September 1931, and British Air Ministry, under influence of such achievement, issued the specification F.7/30 in October 1931. Although it called for modern pursuit airplanes capable of at least 250 mph (400 km/h), seven out of eight entries were biplanes. The only monoplane proposal was Mitchell's Supermarine 224, but the design with a gull wing, fixed undercarriage and Rolls-Royce Goshawk engine was a disappointment because of the lack of speed and poor rate of climb. After that the RAF chose the Gloster Gladiator biplane as the winner.

## Early work

The fiasco with Type 224 did not prevent Mitchell from further work. He persuaded the Supermarine company to fund the work on the completely new design Type 300 using the brand new Rolls-Royce PV12 engine, later known as the Merlin. The Air Ministry expressed interest and issued specification F.37/34 on 28 December 1934 to fund a prototype armed with four wing mounted guns. But by early April 1935 Mitchell received the detail of specification F10/35, calling for eight guns. The change was made on cost of bomb provision removal and reduction of the capacity of the fuel tanks to sixty-six gallons. The decision caused the so called "short legs" of the Spitfire, meaning a lack of range and endurance.

The Supermarine Type 300 made its maiden flight on 5 March 1936, an initial contract to produce 310 Spitfires was signed in June 1936 and the first unit to receive the new fighter was No. 19 Squadron at Duxford in August 1938.

## Catching the progress

The Spitfire's development was an ongoing process from very early stage of its service and incorporated many changes. From the early Mk.I and Mk.II the development reached the point where a more substantial step was required. The Mk.V was a result, but it was in fact a Mk.I powered by the more powerful Merlin 45 series engine. The Mk.V entered service from early 1941, helping the RAF to counteract the Bf 109's development. But in September 1941, a hitherto unknown German radial engine fighter emerged and started to rule the European skies. The new Fw 190 was superior to British fighters, most distressingly even to the Spitfire Mk.V. The losses suffered by the RAF over western Europe rose rapidly and the crisis was serious enough that the RAF ceased most daytime operations during November 1941. The next attempt to resume this type of sorties was made in March 1942. But losses remained unacceptably high, and the RAF was forced to stop offensive operations once again. All this was due to the supremacy of

the Focke-Wulf Fw 190A. The first RAF response to the new situation was the Spitfire Mk.VIII, but the design changes were so complex that initiating timely production was not possible. In June 1942, a German pilot landed by mistake on a British airfield delivering a completely intact Fw 190A fighter into RAF hands. Comparative trials between the Focke-Wulf and Spitfire Mk.V began almost immediately and confirmed the situation over the front – the chance of a Spitfire Mk.V to survive an encounter with the Fw 190s was rather poor. The solution was found in mating the two-stage supercharger Merlin 61 with the fuselage of the Spitfire Mk.Vc.

## Saviour

Two Mk.Vc airframes, AB196 and AB197, were selected for the conversion and their fuselage was strengthened with modified longerons to accommodate the more powerful and heavier engine. The first example was finished on February 26 and the second on March 27, 1942. Flight trials were successful and the order for series production was issued almost immediately. Series production began in June 1942 and the first Mk.IXs found their way to No. 64 Squadron in July. Performance improved significantly. The top speed of 409 mph (658 km/h) at 28,000 feet (8,530 m) was higher by 40 mph (64,4 km/h).

With the Mk.IX the RAF finally got a fighter capable to oppose the Fw 190A. Three main variants of the Mk.IX were produced. The F Mk.IX was powered by the Merlin 61 and was the only version on the assembly line in early 1943. The next was the LF Mk.IX powered by the Merlin 66. This engine was designed to do its best at low-to-medium altitude. The third version, manufactured along with the LF, was the high-altitude HF Mk.IX with the Merlin 70.

The majority of Mk.IXs manufactured were equipped with the so-called C-type wing. Four 20mm cannon or two 20mm cannon and four .303 in machine guns could be installed in the wings. From 1944, E-type wing was produced with four outer .303 machine guns replaced with two .50 heavy machine guns installed in the inner bays. Bomb racks for 250lb bombs were fitted under each wing.

The Mk.IX became the second most numerous mark of the Spitfire with a total of 5653 examples built. The Mk.IX began to replace the Mk.V from June 1942. Thanks to the new fighter, the RAF was ready to fight against the Luftwaffe over occupied Europe.

## The Kit: Spitfire Mk.IXc

The Mk.IXc design developed during the production in several areas. As the "universal" C-type wing was intended to accommodate up to four 20mm cannons, the large blisters allowing such as installation were retained. But the four cannons armament proved quite heavy for Spitfire, so the blisters were narrowed in late series, as the two cannons were usually mounted in the inner position of the double cannon bays. The Merlin 61 engine was replaced by the Merlin 63 unit early in 1943, giving the Mk.IXc some additional power.



Carefully read instruction sheet before assembling. When you use glue or paint, do not use near open flame and use in well ventilated room. Keep out of reach of small children. Children must not be allowed to suck any part, or pull vinyl bag over the head.



Před započítím stavby si pečlivě prostudujte stavební návod. Při používání barev a lepidel pracujte v dobře větrané místnosti. Lepidla ani barvy nepoužívejte v blízkosti otevřeného ohně. Model není určen malým dětem, mohlo by dojít k požití drobných dílů.



OPTIONAL  
VOLBA



BEND  
OHNOUT



SAND  
BROUSIT



OPEN HOLE  
VYVRTAT OTVOR



SYMETRICAL ASSEMBLY  
SYMETRICKÁ MONTÁŽ



REMOVE  
ODŘÍZNOUT



REVERSE SIDE  
OTOČIT



APPLY EDUARD MASK  
AND PAINT  
POUŽÍT EDUARD MASK  
NABARVIT



## PLASTIC PARTS

A&gt;

70120 A

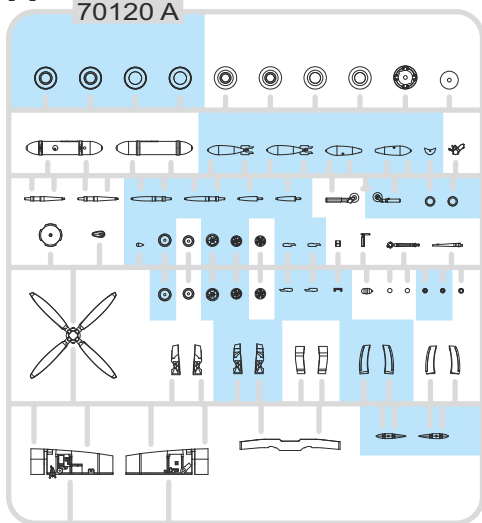

B&gt;

70120 B

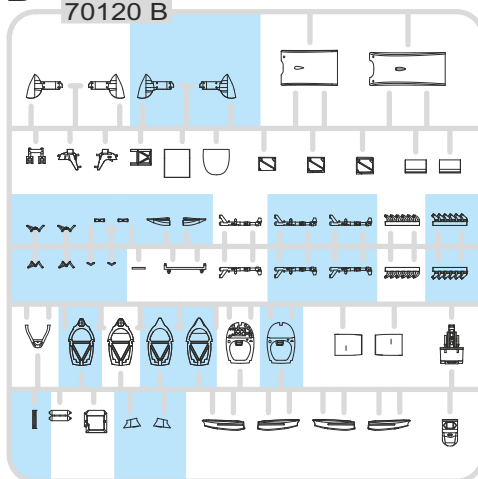

C&gt;

70120 C

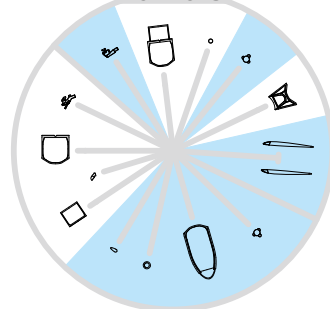

D&gt;

70120 D

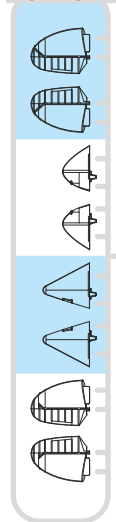

H&gt;

70120 H

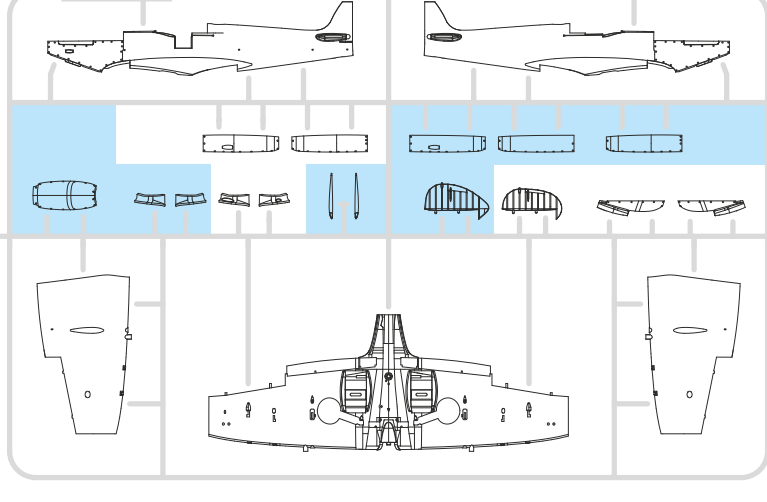

E&gt;

70120 E

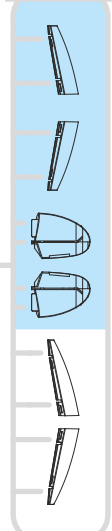

-Parts not for use. -Teile werden nicht verwendet. -Pièces à ne pas utiliser. -Tyto díly nepoužívejte při stavbě. -



GSI Creos (GUNZE)		MISSION MODELS	
AQUEOUS	Mr.COLOR	PAINTS	
[H4]	[C4]	[MMP-007]	YELLOW
[H11]	[C62]	[MMP-001]	FLAT WHITE
[H12]	[C33]	[MMP-047]	FLAT BLACK
[H13]	[C3]	[MMP-003]	FLAT RED
[H33]	[C81]		RUSSET
[H51]	[C11]	[MMP-063]	LIGHT GULL GRAY
[H74]	[C368]	[MMP-080]	SKY
[H77]	[C137]	[MMP-040]	TIRE BLACK
[H327]	[C327]	[MMP-101]	RED

GSI Creos (GUNZE)		MISSION MODELS	
AQUEOUS	Mr.COLOR	PAINTS	
[H330]	[C361]	[MMP-077]	DARK GREEN
[H335]	[C363]	[MMP-094]	MEDIUM SEAGRAY
	[C362]	[MMP-093]	OCEAN GRAY
	[C364]	[MMP-079]	AIRCRAFT GRAY-GREEN
Mr.METAL COLOR		METALLICS	
	[MC214]	[MMM-001]	DARK IRON
	[MC218]	[MMM-003]	ALUMINIUM
Mr.COLOR SUPER METALLIC		METALLICS	
	[SM201]	[MMC-001]	SUPER FINE SILVER

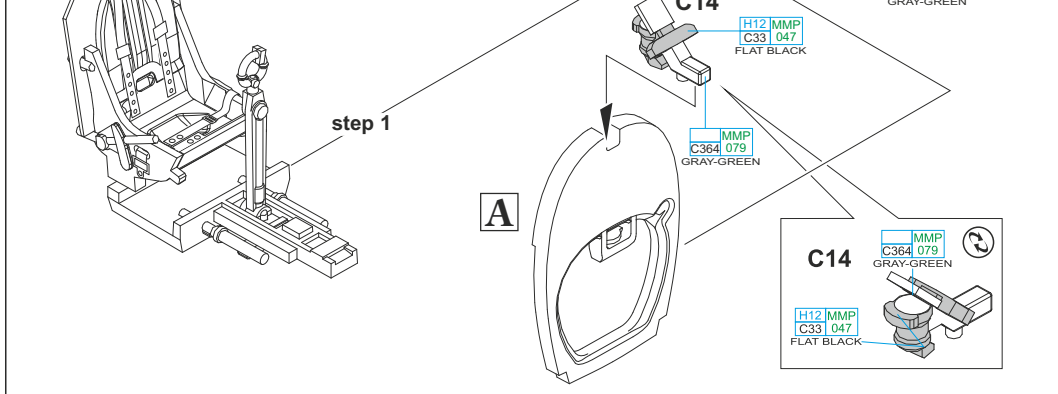
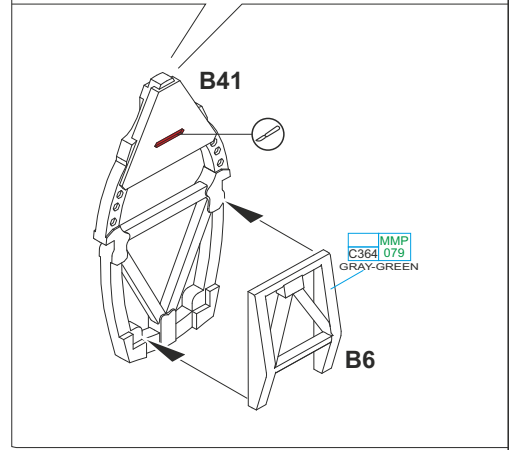
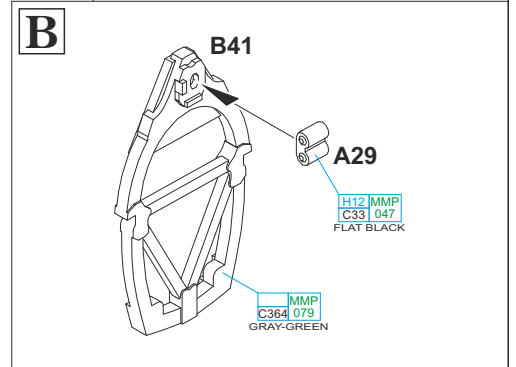
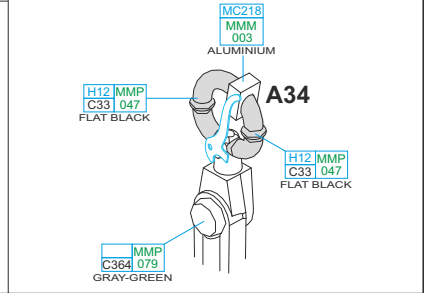
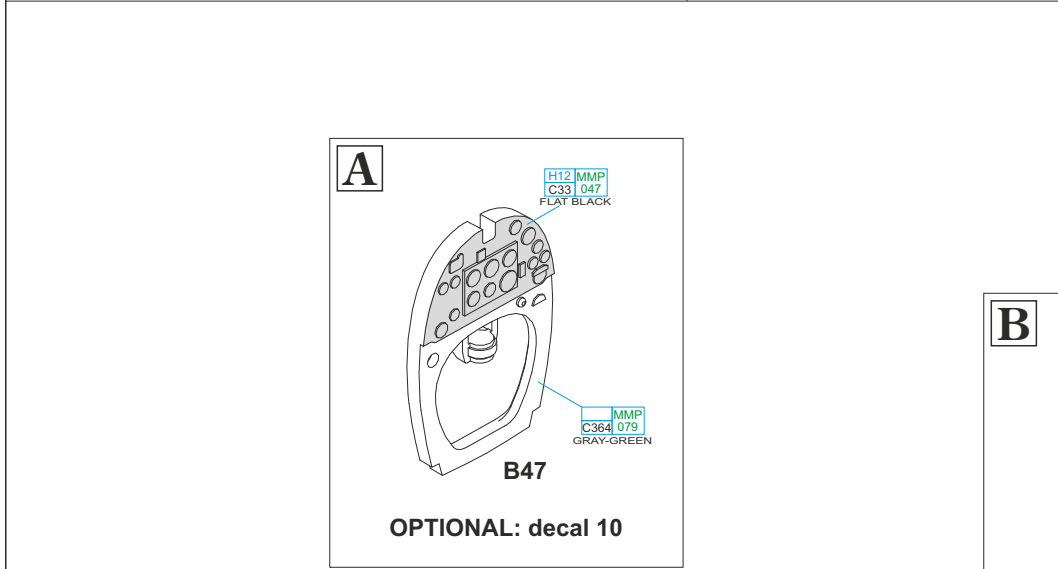
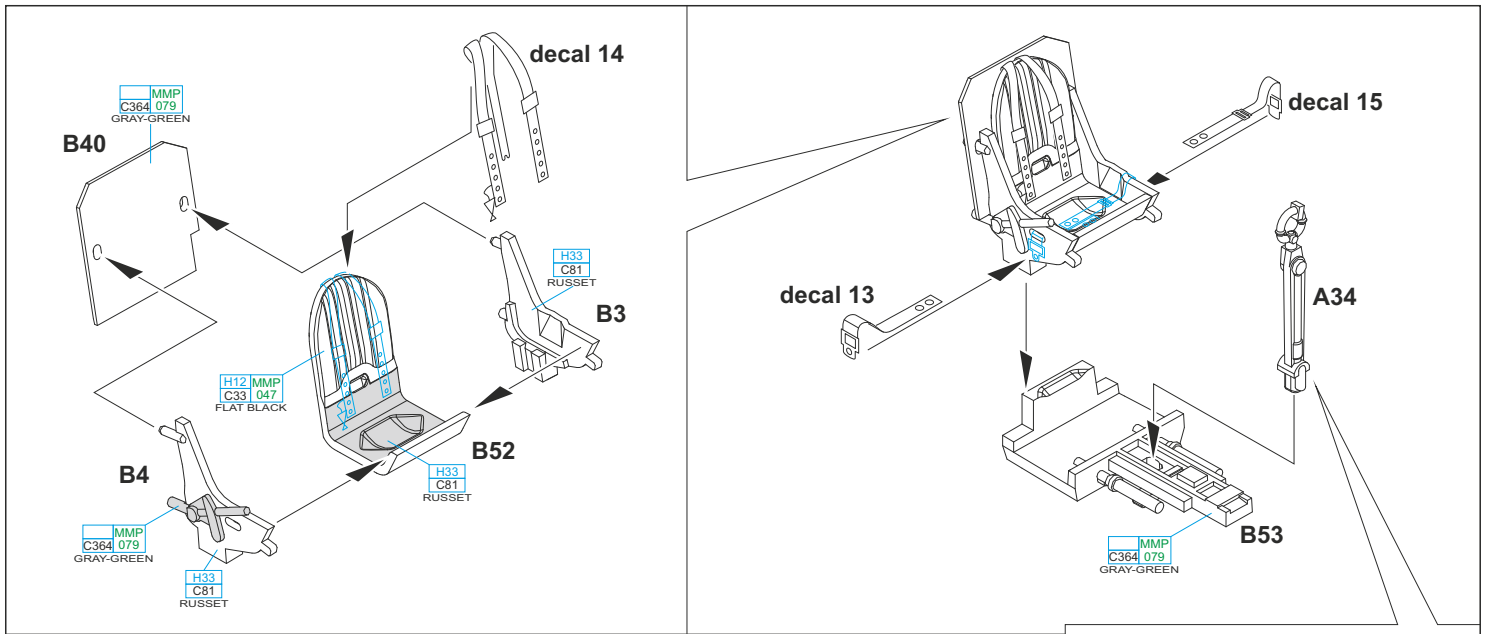

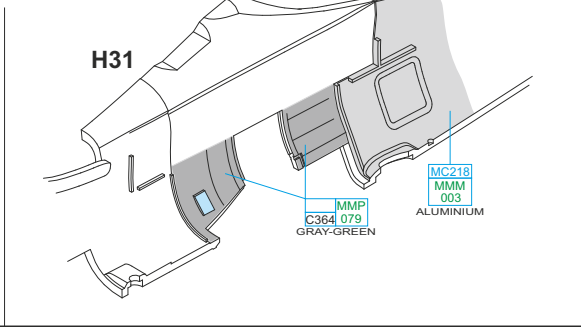
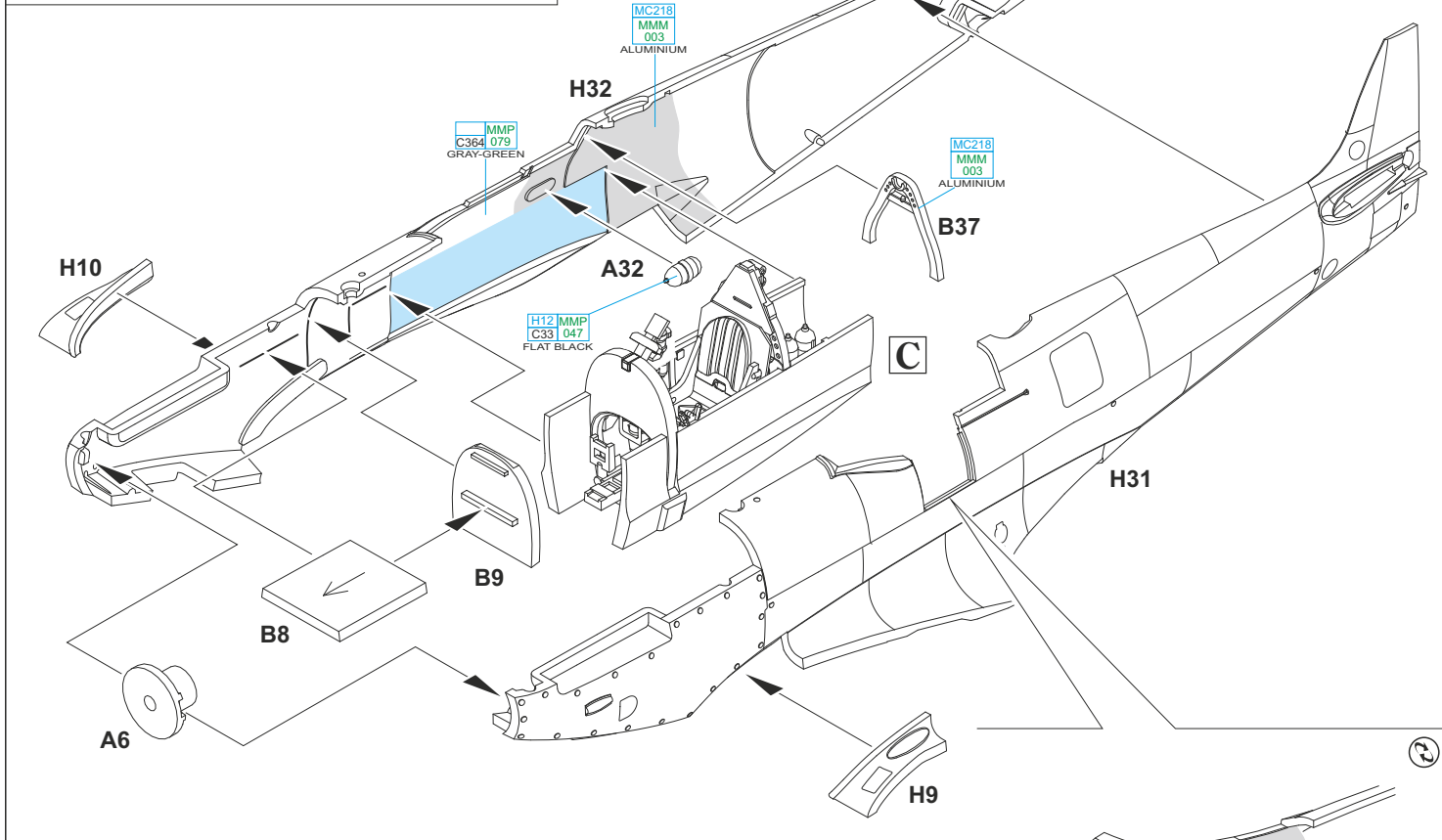
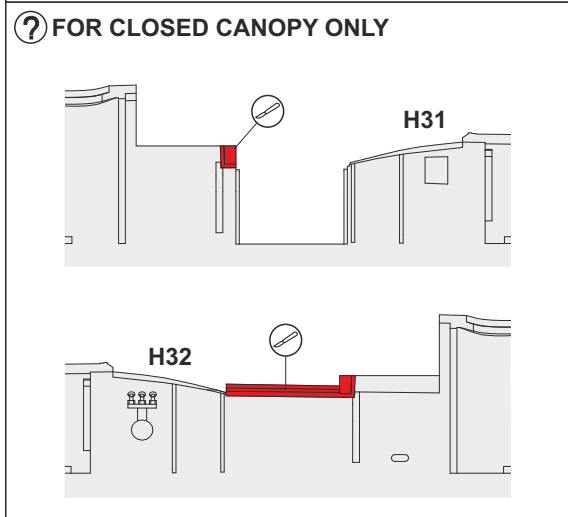
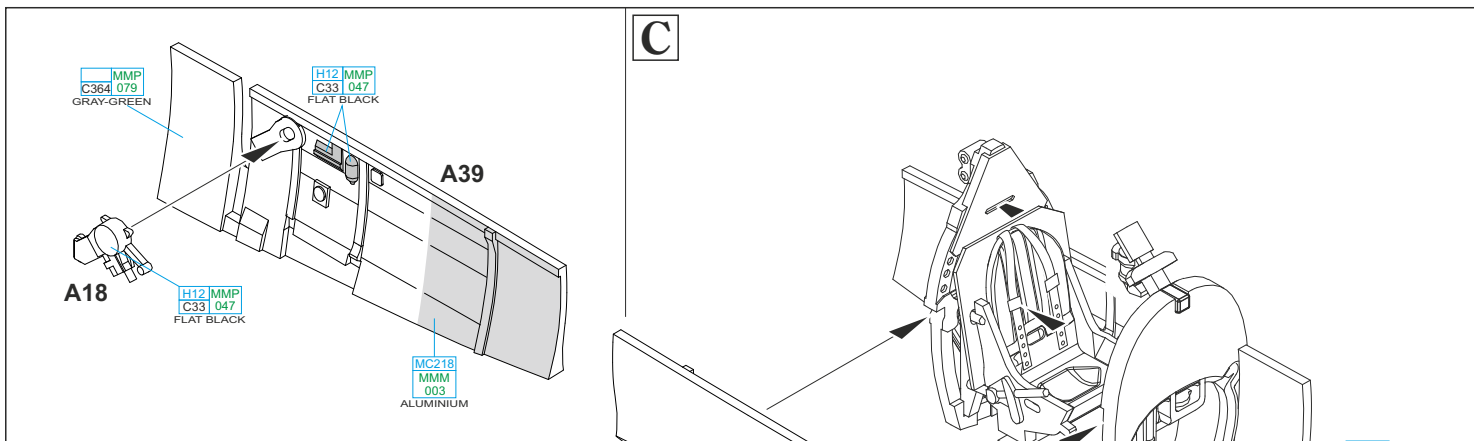

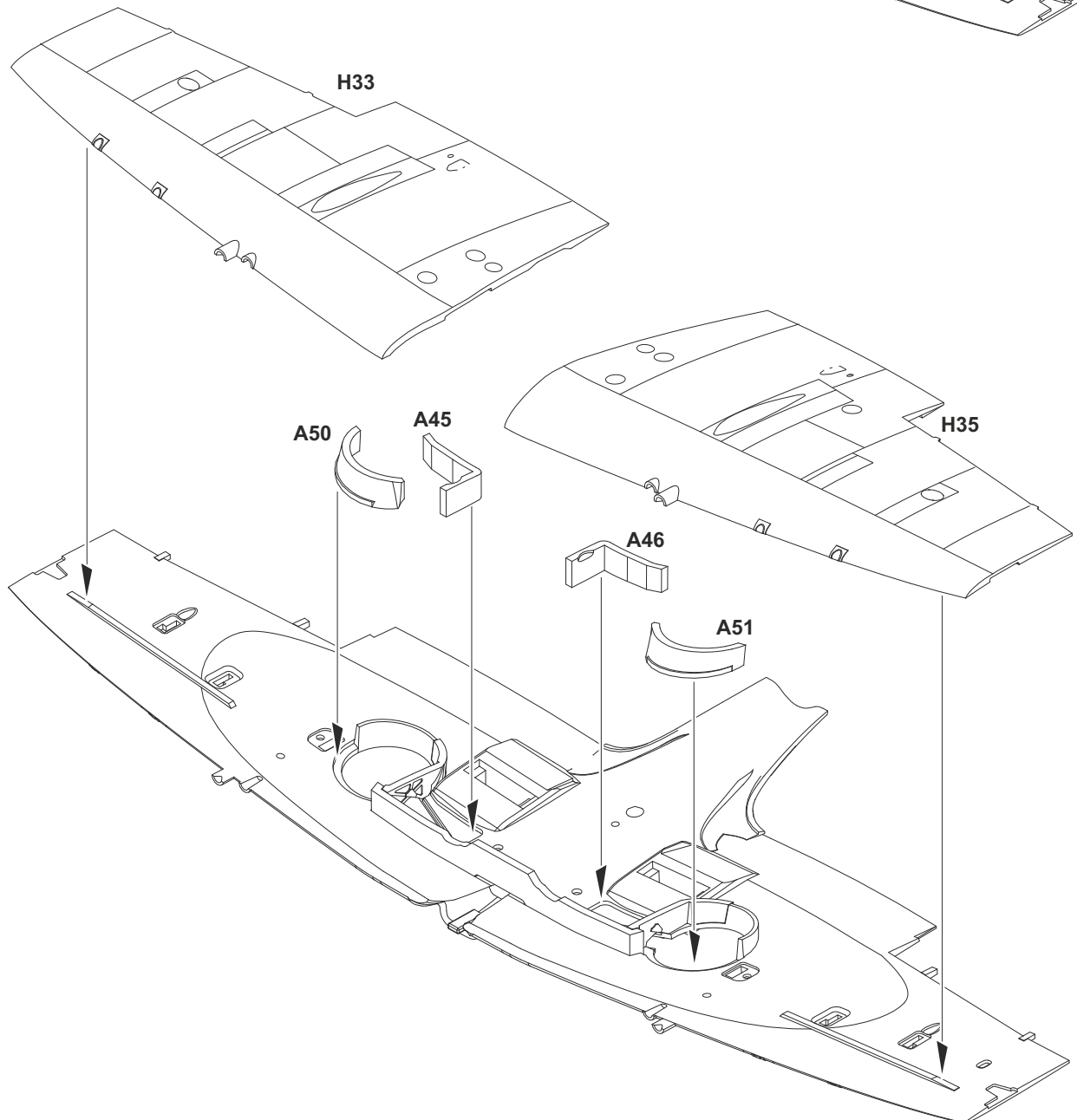
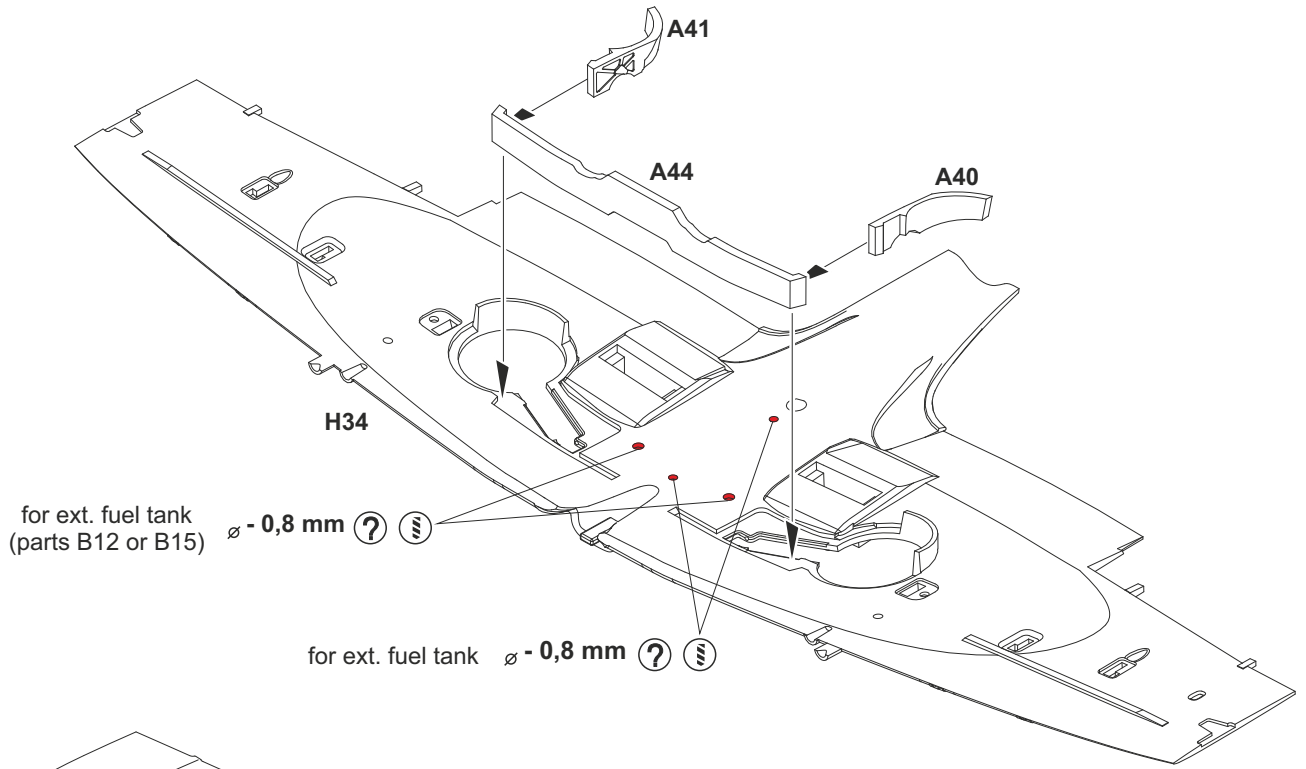



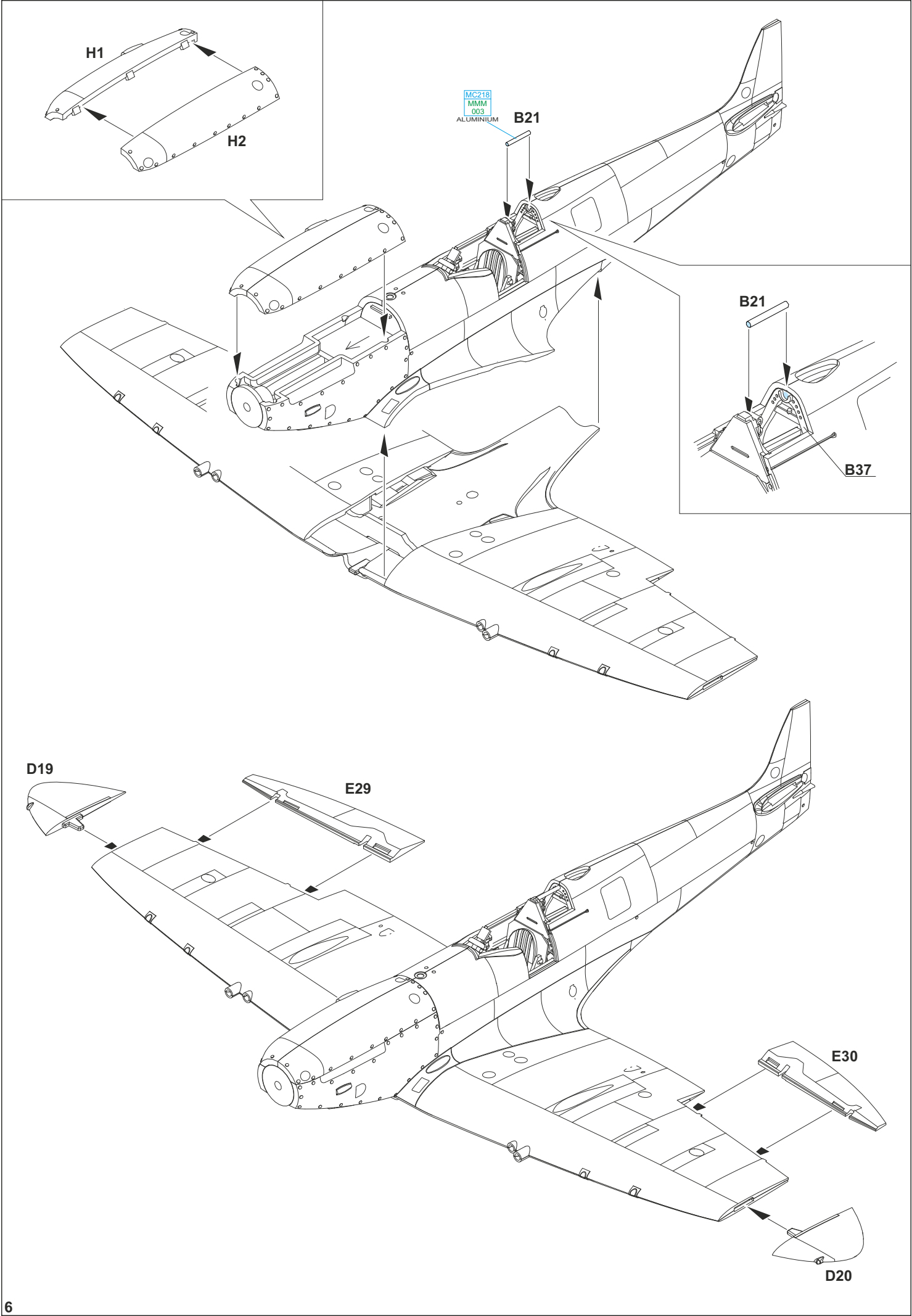

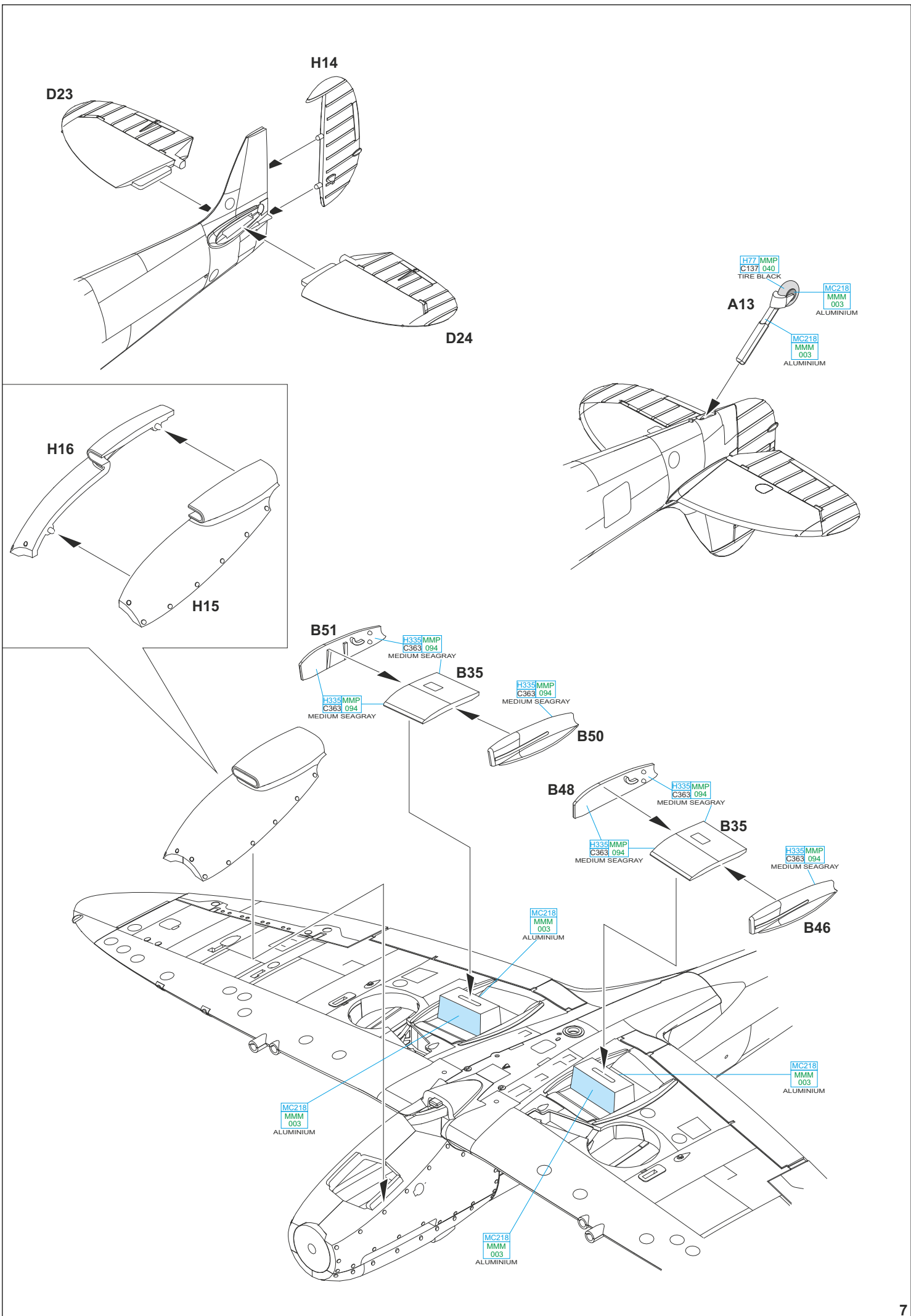

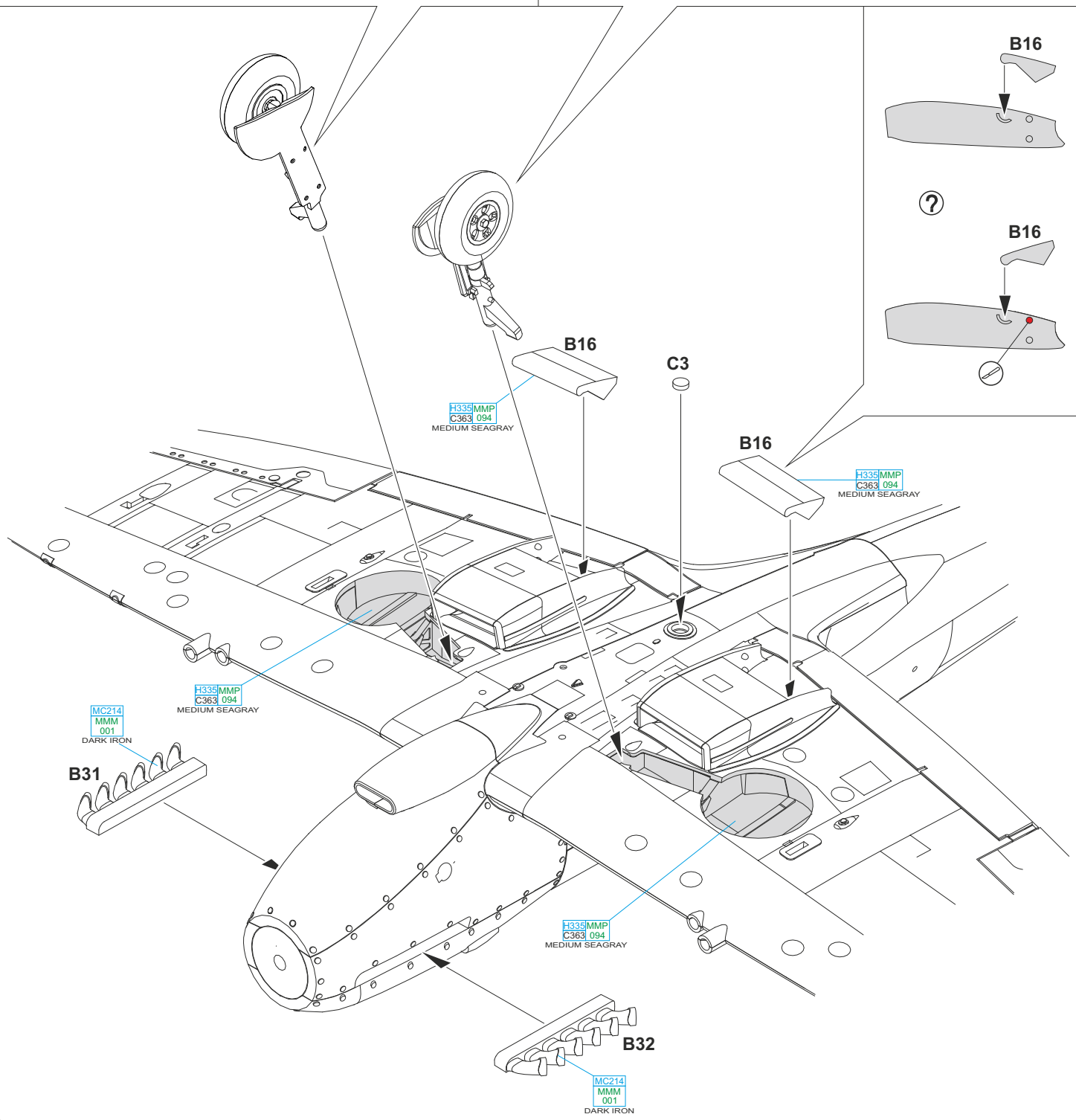
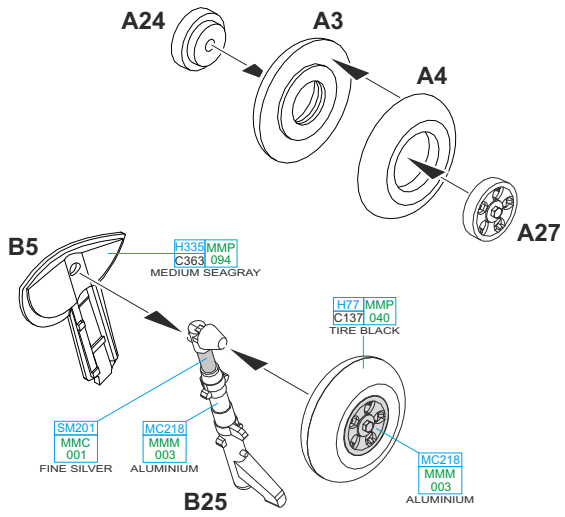
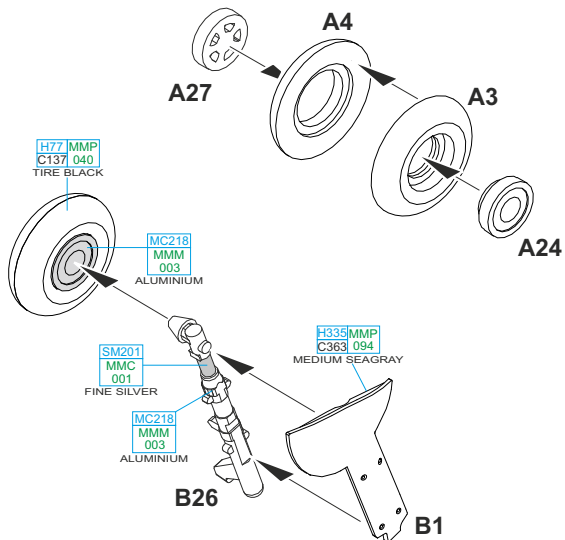



**D**

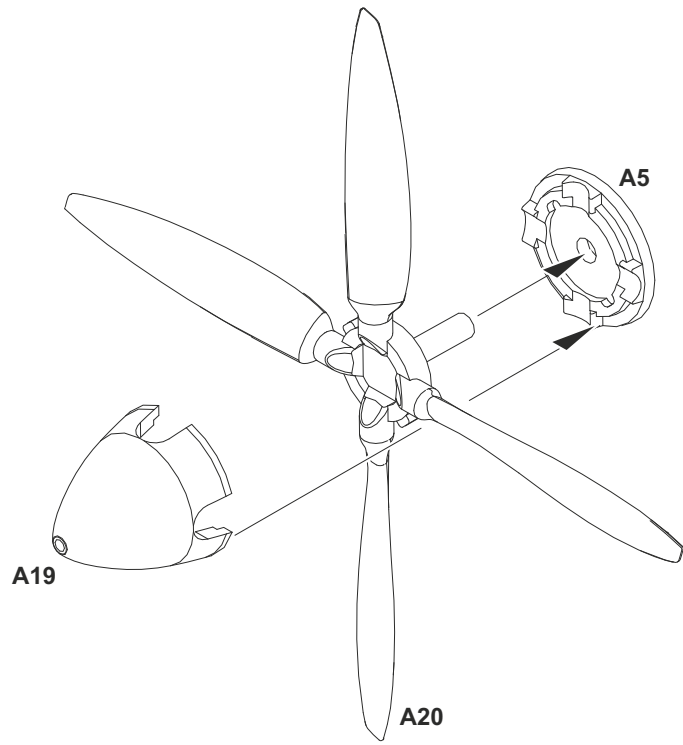

**E**

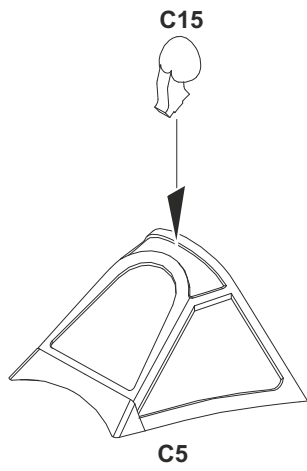

**F**

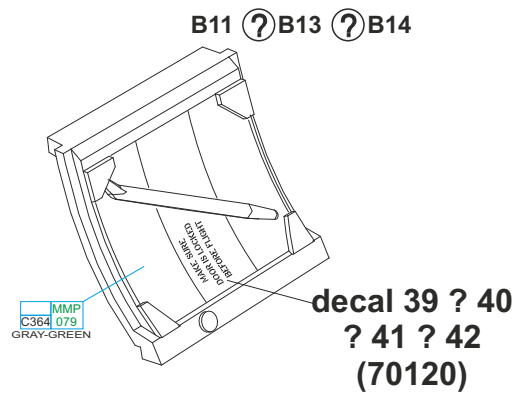

**G** ?

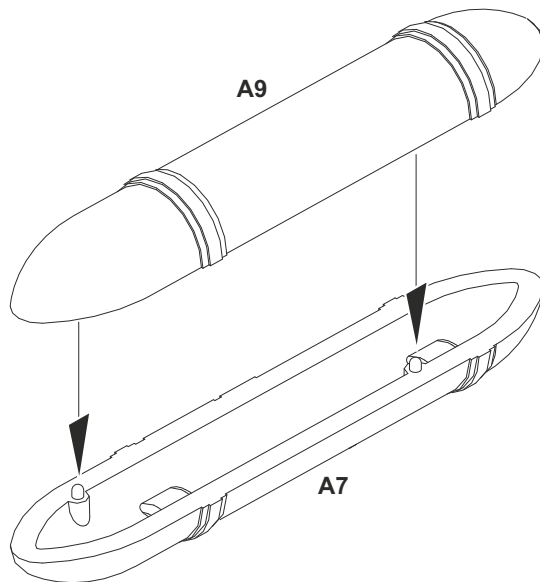

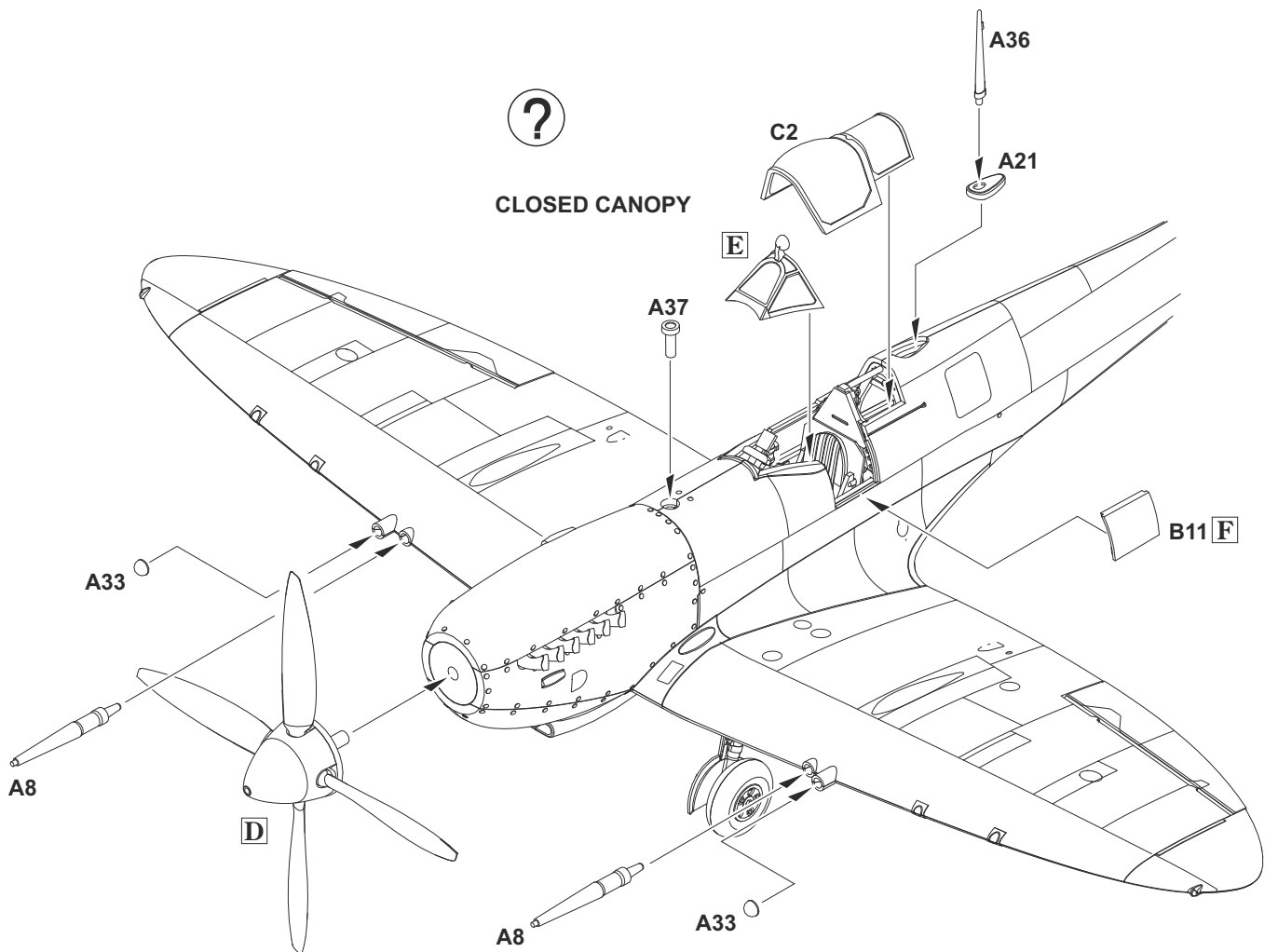
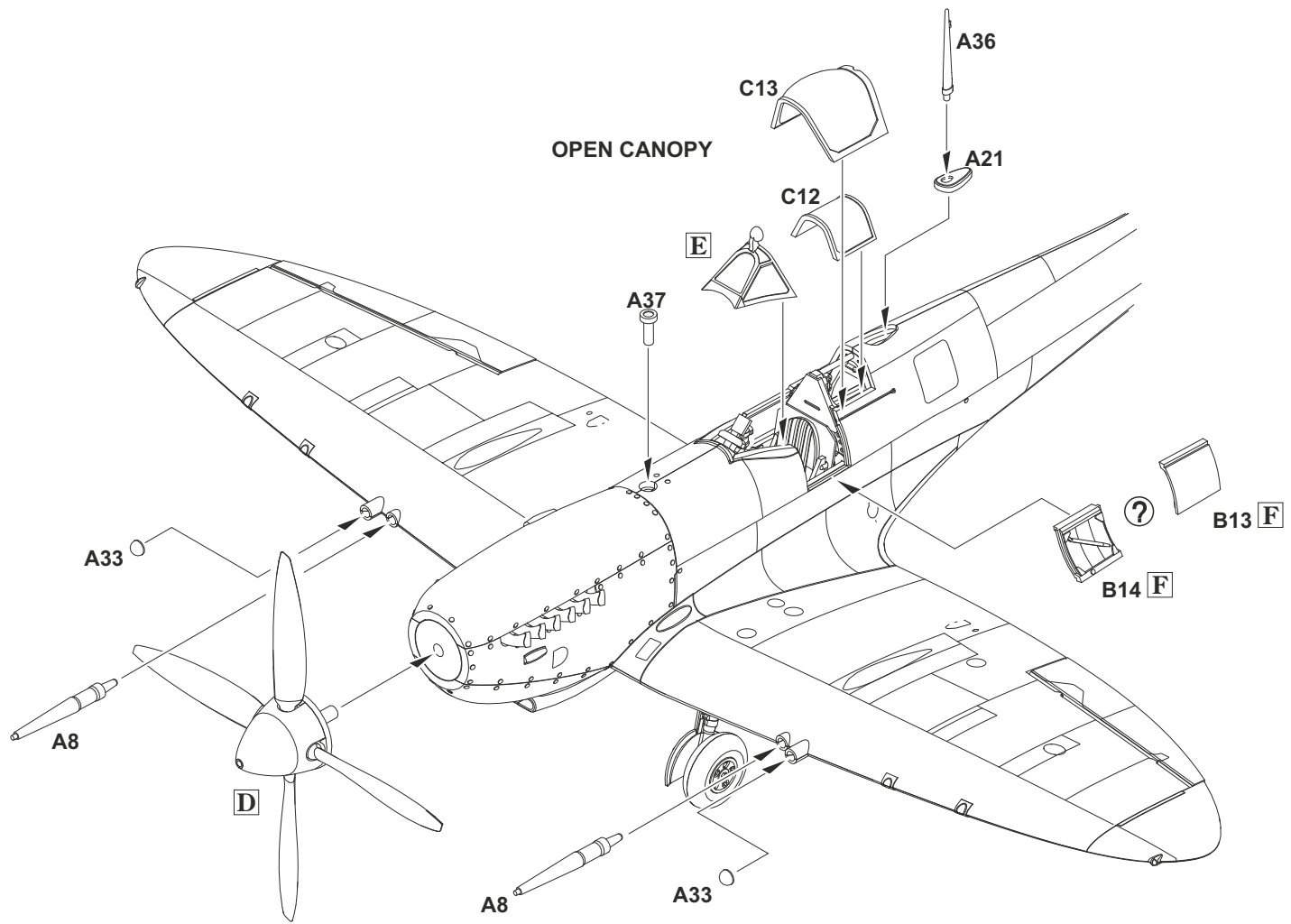

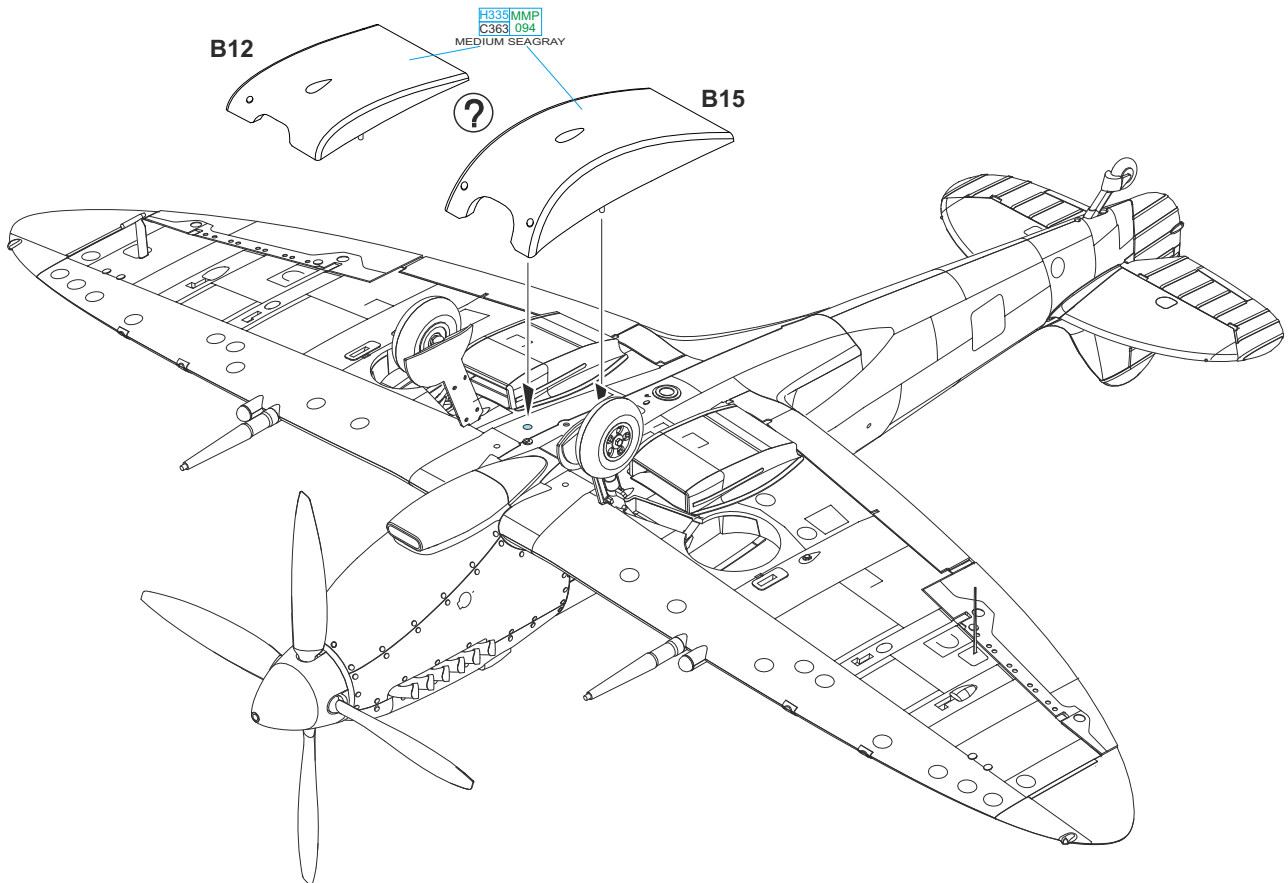
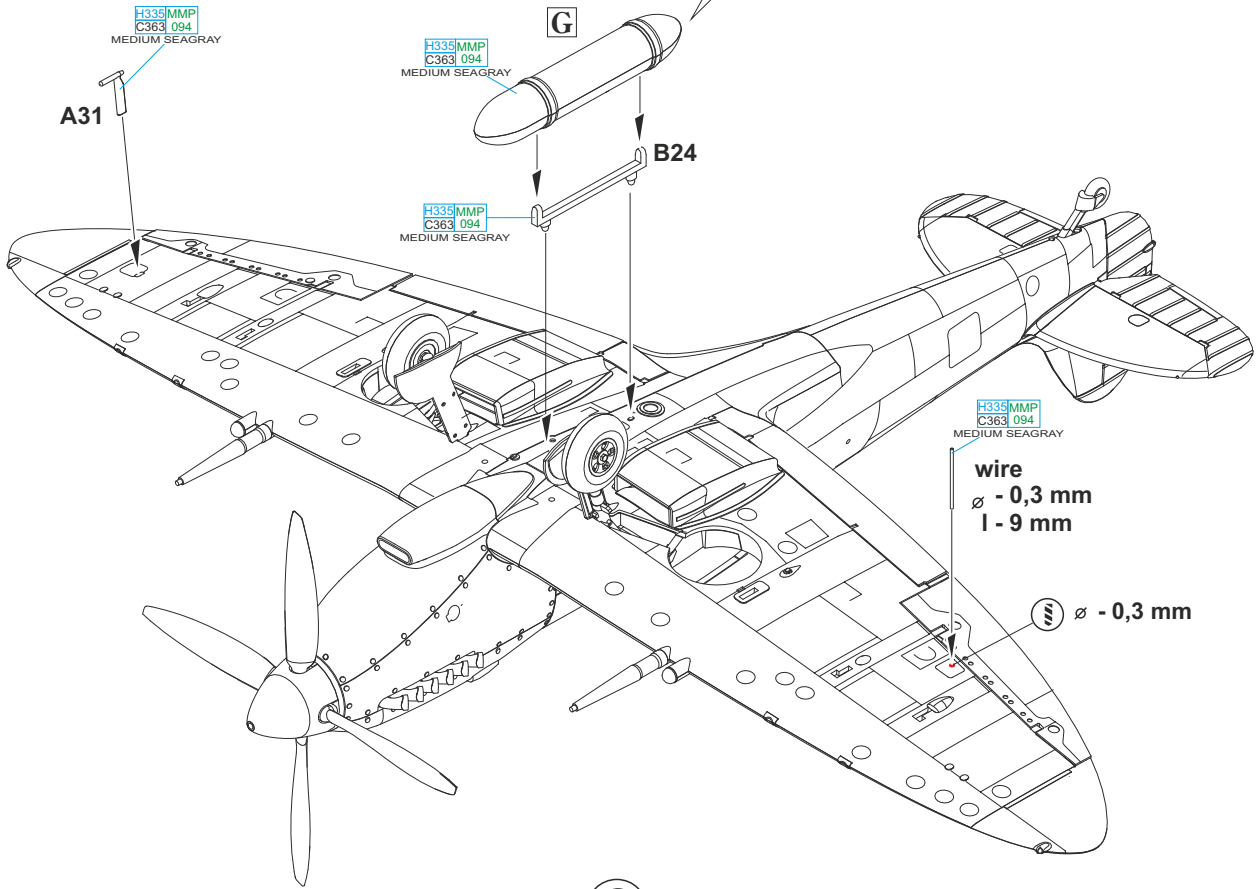
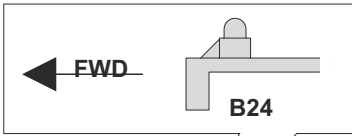

# A MK244, W/Cdr Jan Čermák, No. 312 (Czechoslovak) Squadron, No. 134 Wing, RAF Appledram, United Kingdom, June 1944

The former No. 312 Squadron commander, W/Cdr Jan Čermák was at the time of the Normandy landing the ground and administrative commander of the No. 134 Wing, but regardless he personally led the unit on several missions. One of those was a routine patrol of the Czechoslovak fighters over Sword beach which turned into the large scale air battle. Czechoslovak pilots broke up the formation of a dozen of Focke Wulf Fw 190A, whose goal was to bomb the beach crowded with troops and equipment. Three "onenineties" were destroyed and five damaged at no losses to Czechoslovaks. In this combat W/Cdr Čermák claimed one Fw 190 destroyed and one damaged. On this mission he flew Spitfire s/n MK244 which was the personal aircraft of F/O Jaroslav Šodek who flew it in combat on the regular basis from February to June 1944.

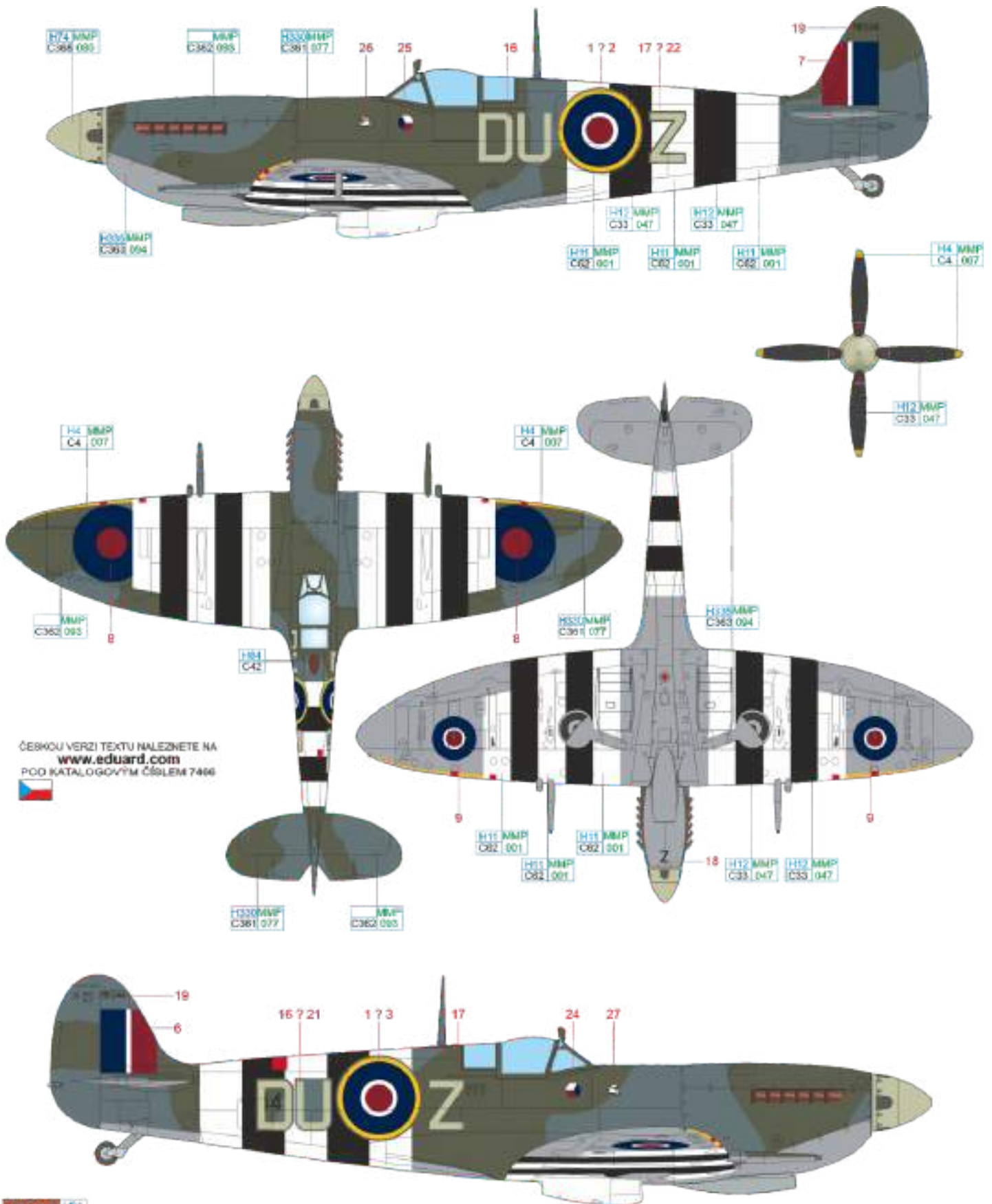

ČERKOU VERZI TEXTU NALEZNETE NA [www.eduard.com](http://www.eduard.com)  
POD KATALOGOVÝM ČÍSLEM 7466



MAHOŠANY	H14 MMP C4 007	OCEAN GRAY	MMP C362 093	DARK GREEN	H12 MMP C361 077	MEDIUM SEA GRAY	H330 MMP C363 094	SKY	H14 MMP C358 080	WHITE	H11 MMP C62 001	BLACK	H12 MMP C33 047	YELLOW	H4 MMP C4 007
----------	----------------	------------	--------------	------------	------------------	-----------------	-------------------	-----	------------------	-------	-----------------	-------	-----------------	--------	---------------





# B MK144, S/Ldr Alan G. Page, No. 132 Squadron, RAF Ford, United Kingdom, February–May 1944

During the Battle of Britain Alan Geoffrey Page was shot down and suffered serious burns. Following two plus years he spent in the hospital recovering. He undertook the plastic surgery in Queen Victoria's Hospital in East Grinstead and became the founding member of the Guinea Pig Club. Ultimately, he managed to return to the active duty and became one of the most successful British fighter pilots. During the spring months of 1944, as the commander of No. 132 Squadron he flew the depicted Spitfire on the offensive bombing and fighter sweeps preceding the invasion. On April 29, on one such mission, over the Deelen airfield in the Netherlands he managed to shoot down a Bf 110G-4 flown by the elite night fighter ace Maj. Hans-Joachim Jabs. On July 7 Page was promoted to command the elite No. 125 Wing. In the end of September, shortly after the conversion to the new powerful Spitfires Mk.XVI, Page's Spitfire was damaged by flak over Arnhem suburbs, and he crash landed. He wounded his face on the gunsight and suffered some other injuries. He was transported by air back to United Kingdom and again admitted to the Queen Victoria's Hospital in East Grinstead. After the war he became an active member of the Battle of Britain Association of the Fighter Pilots and was a moving force behind the creation of the Battle of Britain Memorial which was erected on the cliffs between Dover and Folkestone in 1993. During his wartime career Alan Geoffrey Page shot down 15 enemy aircraft and damaged three of them. His autobiography *The Guinea Pig Story* was published in 1981.

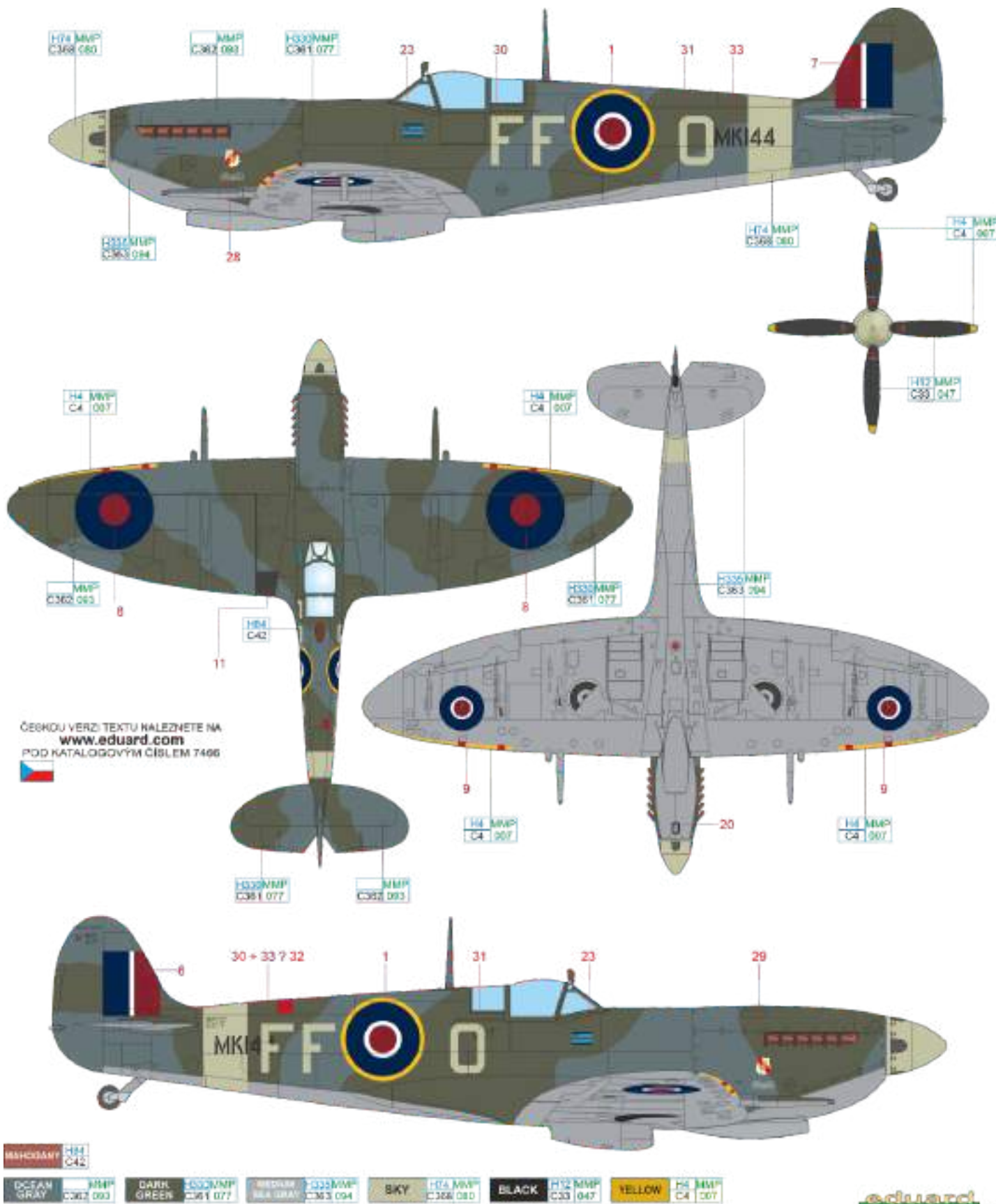



**C** MK832, S/Ldr Robert K. Hayward, No. 411 squadron, B.4 Beny-sur-Mer Airfield, France, July–August 1944

Robert Kitchener "Bob" Hayward comes from the pool of the former RCAF flight instructors who served with No. 126 Wing. He was born on November 12, 1915, in St. John's, Newfoundland. After he completed his pilot training, he served at the main training base CFB Trenton. From February 1941 to October 1942, he flew as an instructor at No. 25 FTS. In March 1943 Hayward stated to fly combat missions with No. 401 Squadron where in the coming months he scored three aerial kills. In May 1944, after the rest, he was again attached to the No. 411 Squadron as a flight leader. On August 5, 1944, he was promoted to the squadron commander and until the end of September 1944 he claimed another three confirmed kills and four enemy aircraft damaged. After he finished his tour of duty he returned to Canada and until March 1945 he again flew as an instructor with No. 25 FTS. From May to September 1945, he briefly served at No. 16 FTS in Hagersville and in November 1945 he retired to the civilian life.

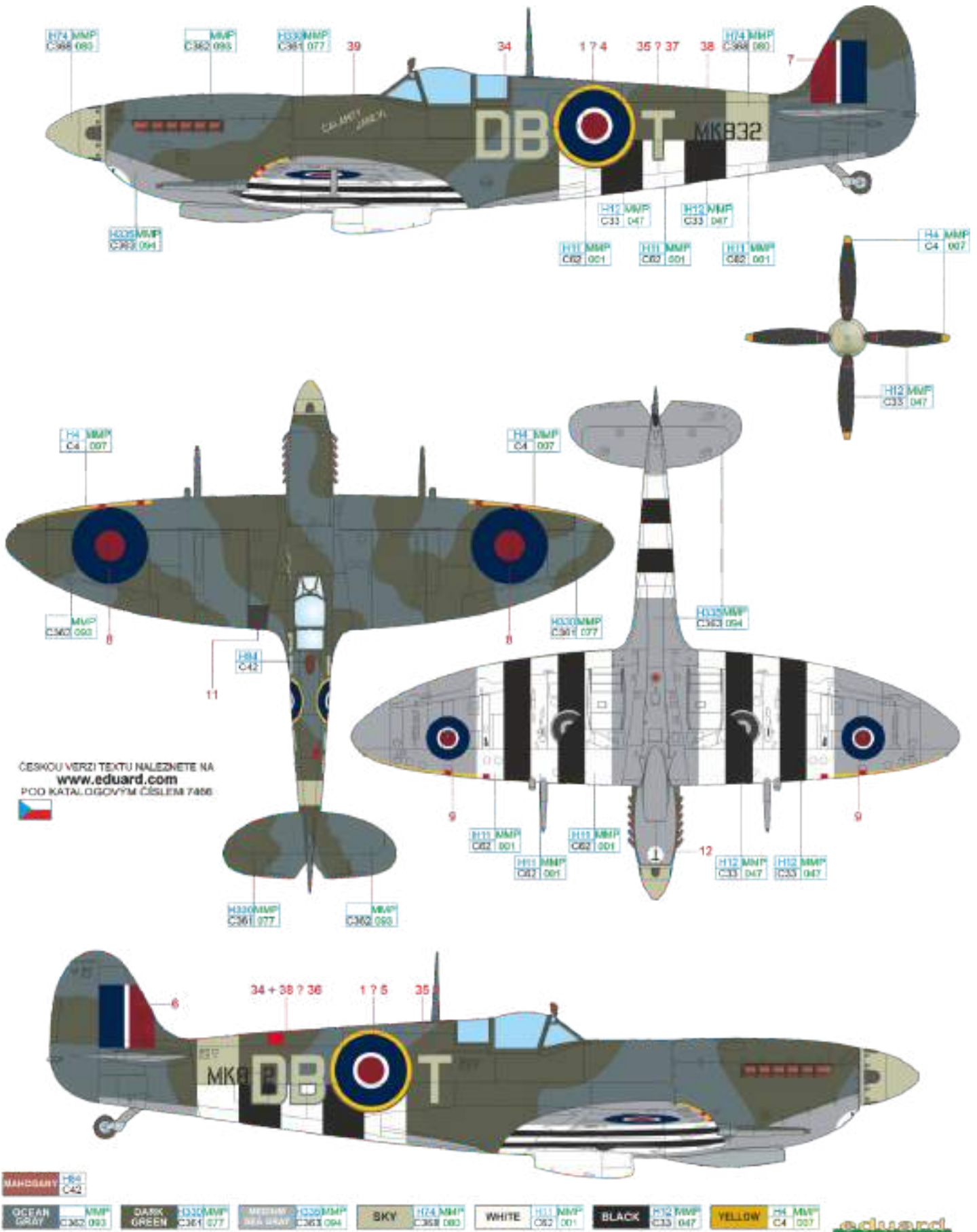

# D Lt. Robert J. Connors, 309<sup>th</sup> FS, 31<sup>st</sup> FG, 12<sup>th</sup> AF, Castel Volturno, Italy, February–March 1944

Lt. Robert Connors' Spitfire carried on the portside of the fuselage the artwork depicting the Porky Pig character which referred to his nickname "Porky". After its arrival in Britain in June 1943 the 309<sup>th</sup> FS was re-equipped with Spitfires Mk.V and flew them in Europe, North Africa, Sicily and Italy. In April 1943 the unit received its first Spitfires Mk.IX often flown as the upper cover for the older Spitfires Mk.V. In March 1944 the 309<sup>th</sup> FS traded their Spitfires for Mustangs possessing much longer range and therefore able to escort the USAAF bombers as far as the Southern Germany.

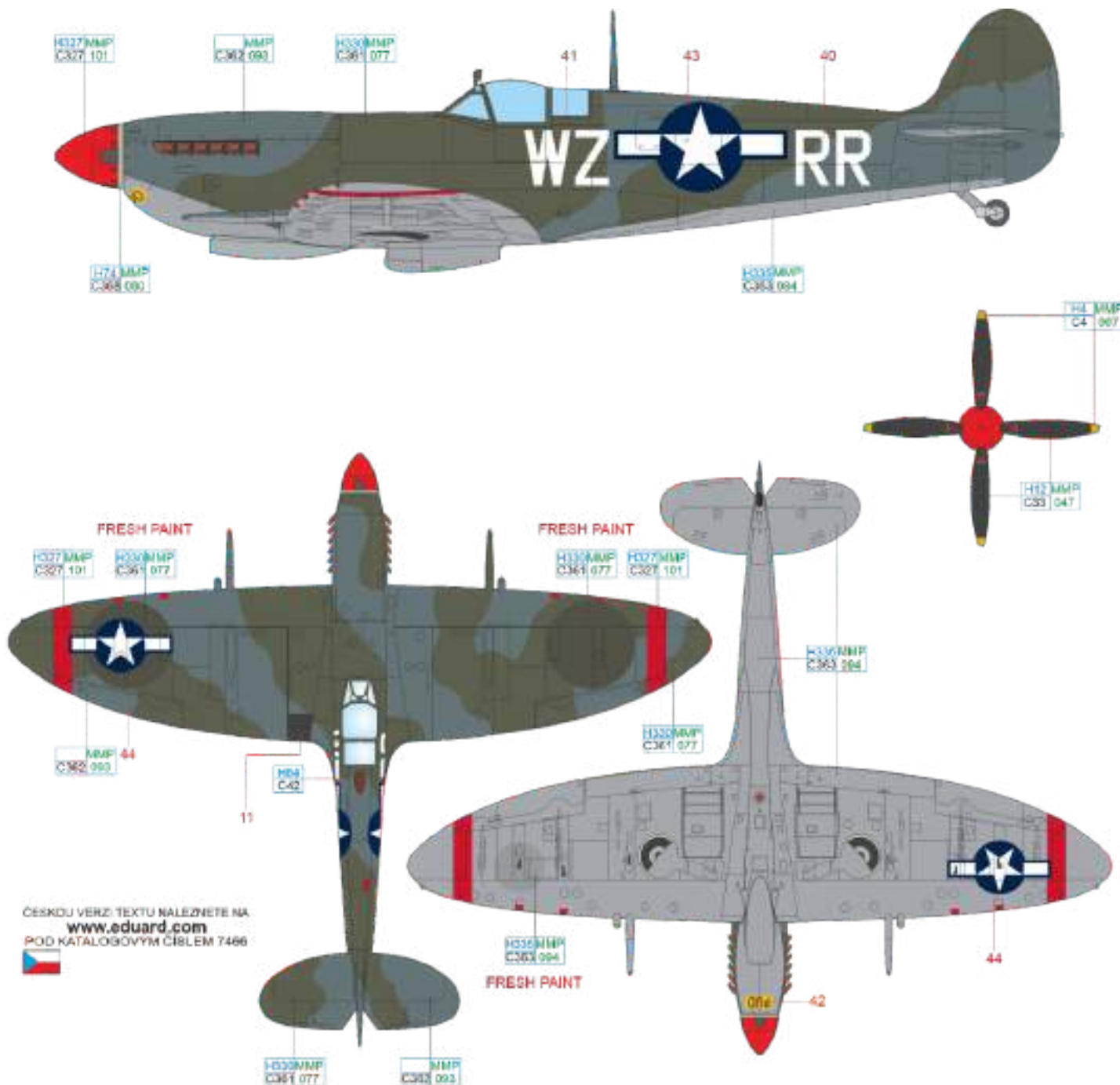

ČESKOU VERZI TEXTU NALEZNETE NA  
[www.eduard.com](http://www.eduard.com)  
 POD KATALOGOVÝM ČÍSLEM 7466

BAHOŠAŘI H44 C42 RED H330MMP C327 101

OCEAN GRAY MMP C362 093 DARK GREEN H330MMP C361 077 MEDIUM BLUE GRAY H330MMP C363 094 SKY H74 MMP C366 080 BLACK H12 MMP C33 047 YELLOW H1 MMP C4 007

# Spitfire Mk.IXc

# STENCILING POSITIONS

